

ELF System

Copper / Fiber :: ELF Family

User Manual



Applies to : ELF-1008-1100 :: ELF-1008-1200 :: ELF-1008-1800 :: ELF-3006-1100 :: ELF-3006-1800
ELF-9704-1119 :: ELF-3004-1800 :: ELF-3206-1200 :: ELF-3206-1900 :: ELF-PC12-SC00
ELF-9716-1900 :: ELF-9716-1700 :: ELF-0005-0001 :: ELF-PC12-FC00 :: ELF-SP12-SCPT
ELF-SP12-FCPT :: ELF-PC12-SA00 :: ELF-SP12-SAPT

ELF System

Copper / Fiber :: ELF Family

Table of Contents

Chapter 1: Descriptions	1
1.1 ELF Copper/Fiber System	1
1.2 ELF Modules.....	1
1.3 ELF Mounting Options	5
1.3.1 ELF Chassis (Model ELF-0000-2400).....	5
1.3.2 Wall-Mount ELF Chassis Bracket (ELF-0000-0900)	7
1.3.3 ELF Wall Bracket (Model ELF-0000-0600)	10
1.3.4 ELF Lockable Wall-Mount Enclosure (Model ELF-0000-0800).....	11
1.4 System-Level Applications.....	13
1.5 Installation Considerations.....	13
1.5.1 Location and Space	13
1.5.2 Tools and Equipment.....	13
1.5.3 Inspection.....	14
1.5.4 Technical Support (USA).....	14
1.6 Specifications.....	14
Chapter 2: ELF DS1 Modules.....	17
2.1 ELF 8-Termination DSX-1, Wire-Wrap I/O (Model ELF-1008-1100).....	17
2.2 ELF 8-Termination DSX-1, BNC I/O (Model 1008-1200)	19
2.3 ELF 8-Termination DSX-1, RJ48C I/O (Model ELF-1008-1800).....	21
2.4 ELF 6-Termination DSX-1, Wire-Wrap I/O (Model ELF-3006-1100).....	23
2.5 ELF 6-Termination DSX-1, RJ48C I/O (Model ELF-3006-1800).....	24
2.6 ELF 4-Circuit DNI-1, Wire-Wrap I/O to RJ48C I/O (Model ELF-9704-1119)	25
2.7 ELF 4-Circuit DNI-1, RJ48C I/O to RJ48C I/O (Model ELF-3004-1800).....	27
Chapter 3: ELF DS3 Modules.....	29
3.1 ELF 2-Termination DSX-3, Rear BNC I/O (Model ELF-3206-1200)	29
3.2 ELF 1-Termination DSX-3, TFA BNC I/O (Model ELF-3206-1900).....	31
Chapter 4: ELF Fiber Modules.....	33
4.1 ELF Fiber Patch Modules (Model Series ELF-PC12)	33
4.2 ELF Fiber Splice/Patch Modules (Model Series ELF-SP12)	34
Chapter 5: ELF Multi-Purpose Modules.....	37
5.1 ELF RJ45C to RJ45C Patch Module (Model ELF-9716-1900)	38
5.2 ELF RJ45-IDC Patch Module (Model ELF-9716-1700)	39
5.3 ELF 12 x 4 Alarm Pin Block Module (Model ELF-0005-0001)	40
Chapter 6: Service	41
6.1 Owner Maintenance.....	41
6.2 Service.....	41
6.2.1 In-Warranty Service	41
6.2.2 Out-Of-Warranty Service.....	41
6.3 Repacking For Shipment	41
Chapter 7: Accessories.....	42

ELF System

Copper / Fiber :: ELF Family

List of Figures

Figure 1 - ELF Chassis Mounting Options.....	6
Figure 2 - Installing ELF Chassis on a Rack.....	7
Figure 3 - Grounding an ELF Chassis	7
Figure 4 - Bracket	7
Figure 5 - Wall-Mount ELF Chassis Bracket Dimensions	8
Figure 6 - Wall-Mount ELF Chassis Bracket Installation.....	9
Figure 7 - ELF Wall Bracket Dimensions	10
Figure 8 - Typical ELF Wall Bracket Installation	10
Figure 9 - ELF Lockable Wall-Mount Enclosure	11
Figure 10 - ELF Lockable Wall-Mount Dimensions.....	12
Figure 11 - Model ELF-1008-1100 Dimensions	17
Figure 12 - Model ELF-1008-1100 Reference Schematic	18
Figure 13 - Model 1008-1200 Dimensions.....	19
Figure 14 - Model 1008-1200 Reference Schematic.....	20
Figure 15 - Model ELF-1008-1800 Dimensions.....	21
Figure 16 - Model ELF-1008-1800 Reference Schematic	22
Figure 17 - Model ELF-3006-1100 Dimensions	23
Figure 18 - Model ELF-3006-1100 Reference Schematic	23
Figure 19 - Model ELF-3006-1800 Dimensions.....	24
Figure 20 - Model ELF-3006-1800 Reference Schematic	24
Figure 21 - Model ELF-9704-1119 Dimensions	25
Figure 22 - Model ELF-9704-1119 Reference Schematic.....	26
Figure 23 - Model ELF-3004-1800 Dimensions.....	27
Figure 24 - Model ELF-3004-1800 Reference Schematic	27
Figure 25 - Model ELF-3206-1200 Dimensions.....	29
Figure 26 - Model ELF-3206-1200 Reference Schematic	30
Figure 27 - Model ELF-3206-1900 Dimensions.....	31
Figure 28 - Model ELF-3206-1900 Reference Schematic	31
Figure 29 - ELF-PC12-SC00	33
Figure 30 - ELF Patch Module (Model ELF-PC12-SCxx, Typical Cabling.....	34
Figure 31 - Model Series ELF-SP12 Parts & Dimensions	34
Figure 32 - Splice Cassette	35
Figure 33 - Subunit Entrance Compartment.....	35
Figure 34 - ELF Splice/Patch Module	36
Figure 35 - Model ELF-9716-1900 Parts & Dimensions	38
Figure 36 - Model ELF-9716-1900 Schematic.....	38
Figure 37 - Model ELF-9716-1700 Parts & Dimensions	39
Figure 38 - Model ELF-9716-1700 Schematic.....	39
Figure 39 - Example of Model ELF-9716-1700 finished cable and wiring	40
Figure 40 - Model ELF-0005-0001 Parts & Dimensions	40

ELF System

Copper / Fiber :: ELF Family

Chapter 1: Descriptions

1.1 ELF Copper/Fiber System

Telect's ELF System is a small "edge" connection system for use in locations where equipment density — maximum density with simplified monitoring — is important. The ELF System is ideal for a 3G, 4G, LTE wireless network at a base transceiver station (BTS), customer premises, controlled environment vault, co-location, or at any remote network terminal.

All ELF Systems consists of a chassis, wall brackets, or wall enclosures with DSX-1, DNI, DSX-3, Fiber, and/or Ethernet/Data modules:

- ELF Chassis fit equipment cabinets, 19-in. or 23-in. EIA/WECO racks, or Telect's Wall-Mount ELF Chassis Bracket. Each 1RU (1RU = 1.75 in.) chassis handles up to three, rear- and/or front-access ELF modules. DSX-1, DSX-3, fiber, and other ELF modules can be mixed in the same chassis.
- Single-Module ELF Wall Brackets mount to the walls. Each bracket accommodates one total front-access ELF module
- Single-Module ELF Wall enclosures include a lockable access door. The enclosure mounts to the wall and accommodates one rear- and/or front-access ELF module. Ideal for a Fiber ELF module.

All chassis, brackets, and enclosures include shield ground pins for ITU G.703 compliance. ELF modules are passive devices and do not require power. All chassis, enclosure, brackets, and modules are mainly black.



1.2 ELF Modules

The cover shows a composite of all ELF modules and mounting options.

The following identifies all ELF DSX1, DSX3, fiber, and signal-manager modules offered by Telect, along with section and page references. Mounting options (chassis and wall mount) are covered in this section.

ELF System

Copper / Fiber :: ELF Family

ELF Module	Configuration	ELF Model Number	Page	Illustration
DSX-1				
8-Termination	REAR — Wire-Wrap I/O FRONT — Wire-Wrap XC • 3-Port Bantam Patch Jacks	ELF-1008-1100	17	
	REAR — BNC I/O FRONT — Wire-Wrap XC • 3-Port Bantam Patch Jacks	ELF-1008-1200	19	
	REAR — RJ48C I/O FRONT — Wire-Wrap XC • 3-Port Bantam Patch Jacks	ELF-1008-1800	21	
6-Termination (See Note.)	TOTAL FRONT ACCESS — • Wire-Wrap I/O • Wire-Wrap XC • 3-Port Bantam Patch Jacks	ELF-3006-1100	23	
	TOTAL FRONT ACCESS — • RJ48C I/O • RJ48C XC • 3-Port Bantam Patch Jacks	ELF-3006-1800	24	
DNI-1				
NOTE: All DS1 and DS3 Total Front Access and 12x4 Alarm Pin Block ELF Modules fit Telect's ELF Wall Bracket (ELF-000-0600).				



ELF System

Copper / Fiber :: ELF Family

ELF Module	Configuration	ELF Model Number	Page	Illustration
4-Circuit Interconnect	REAR — • Wire-Wrap NE1 I/O FRONT — • RJ48C NE2 I/O • 3-Port Bantam Patch Jacks for all NEs	ELF-9704-1119	25	
	TOTAL FRONT ACCESS(See Note.) — • RJ48C NE1 I/O • RJ48C NE2 I/O • 3-Port Bantam Patch Jacks for all NEs	ELF-3004-1800	27	
DSX-3				
2-Termination 1-Termination (See Note.)	REAR — • BNC I/O & XC FRONT — • 6-Port Mini-WECO Jacks	ELF-3206-1200	29	
	TOTAL FRONT ACCESS — • BNC I/O & XC • 6-Port Mini-WECO Jacks	ELF-3206-1900	31	
Fiber				
12-Termination Patch	REAR — • Fiber Jumpers from NEs FRONT — • Fiber Adapters	ELF-PC12-SC00 ELF-PC12-FC00	33	
NOTE: All DS1 and DS3 Total Front Access and 12x4 Alarm Pin Block ELF Modules fit Telect's ELF Wall Bracket (ELF-000-0600).				



ELF System

Copper / Fiber :: ELF Family

ELF Module	Configuration	ELF Model Number	Page	Illustration
12-Termination Splice/Patch	REAR – • Subunit Entrance FRONT – • Fiber Adapters	ELF-SP12-SCPT ELF-SP12-FCPT	34	
12-Termination SC-APC Patch Module	REAR – • Fiber Jumpers from NES FRONT – • Fiber Adapters	ELF-PC12-SA00	33	
12-Termination SC/APC Patch and Splice Module	REAR – • Subunit Entrance FRONT – • Fiber Adapters	ELF-SP12-SAPT	33	
General Purpose Signal Management				
NOTE: All DS1 and DS3 Total Front Access and 12x4 Alarm Pin Block ELF Modules fit Telect's ELF Wall Bracket (ELF-000-0600).				

ELF System

Copper / Fiber :: ELF Family

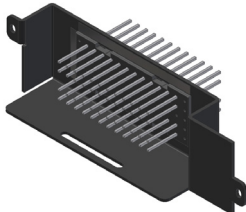
ELF Module	Configuration	ELF Model Number	Page	Illustration
16-Circuit Patch	REAR — • 16, RJ45Cs FRONT — • 16, RJ45Cs	ELF-9716-1900	38	
	REAR — • 16 IDC Punch-Down Blocks FRONT — • 16, RJ45s	ELF-9716-1700	39	
12 x 4 Alarm Pin Block (See Note.)	Bulkhead-Style Pin Block	ELF-0005-0001	40	

NOTE: All DS1 and DS3 Total Front Access and 12x4 Alarm Pin Block ELF Modules fit Telect's ELF Wall Bracket (ELF-000-0600).

1.3 ELF Mounting Options

1.3.1 ELF Chassis (Model ELF-0000-2400)

- High-density 1RU chassis accommodates three ELF modules.
- Fully enclosed environment provides robust RF protection.
- Reversible mounting brackets available for 19-in. or 23-in. EIA/WECO racks. (Rack-mounting hardware included.) Chassis brackets also fit Telect's Wall-Mount ELF Chassis Bracket.
- Total termination capacity per chassis:
 - 18 or 24 DSX-1
 - 12 DNI
 - 3 or 6 DSX-3
 - 36 fiber splices/patches
 - 48 RJ45C-to-RJ45C patches
 - 36 alarm interconnects

ELF System

Copper / Fiber :: ELF Family

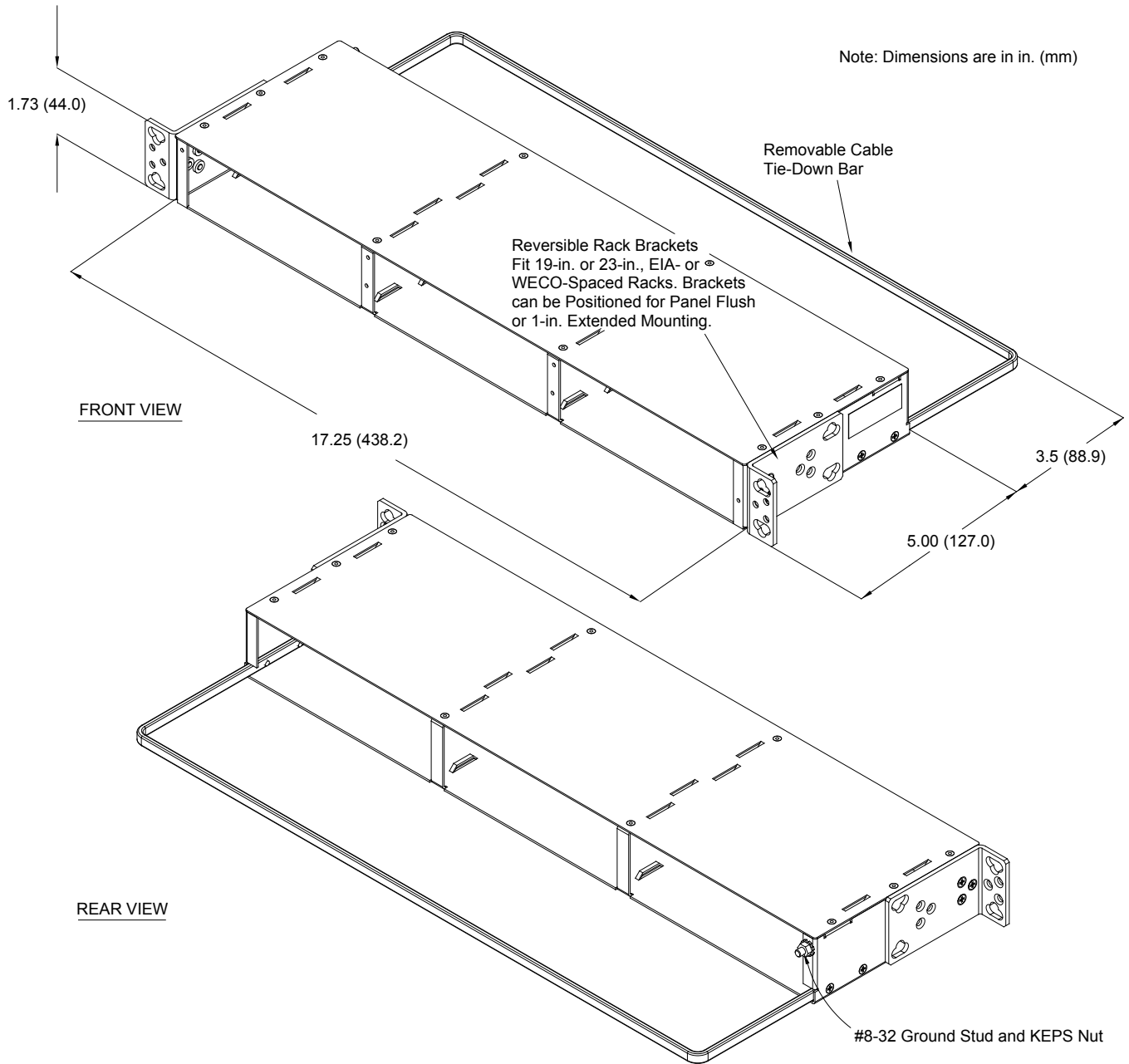

Figure 1 - ELF Chassis Mounting Options

ELF System

Copper / Fiber :: ELF Family

The following illustrations show a typical installation.

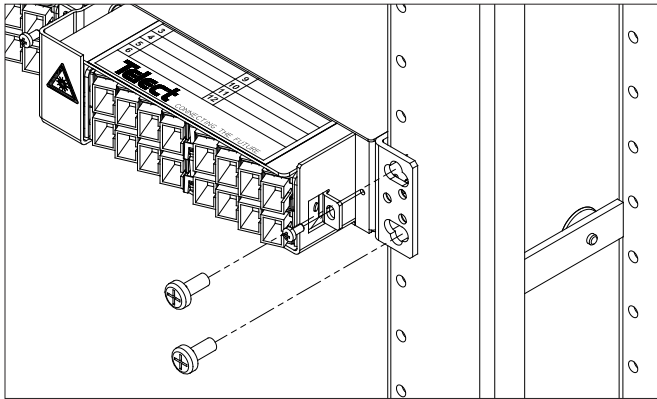

Figure 2 - Installing ELF Chassis on a Rack

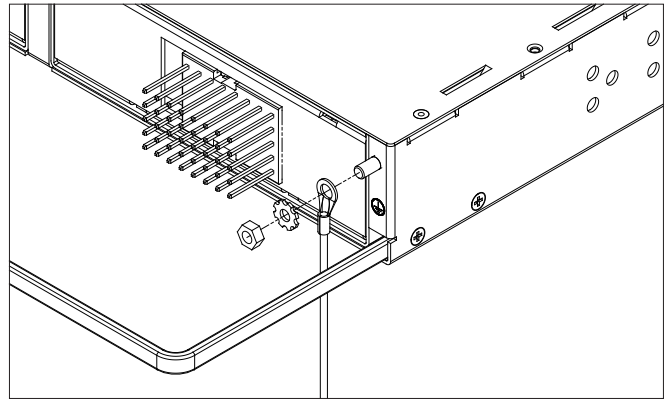

Figure 3 - Grounding an ELF Chassis

1.3.2 Wall-Mount ELF Chassis Bracket (ELF-0000-0900)

Telect's Wall-Mount ELF Chassis Bracket is designed to hold one ELF Chassis (ELF-0000-2400) against a wall or side of a cabinet. The chassis bracket allows an ELF chassis with either rear- and/or front-access modules to either extend from a wall or cabinet using a minimum wall "footprint" or to hug the wall or cabinet with a minimum profile. Wall-mounting hardware is not included.

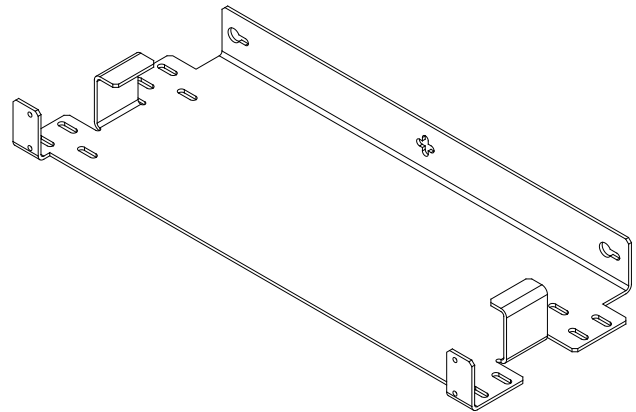

Figure 4 - Bracket

ELF System

Copper / Fiber :: ELF Family

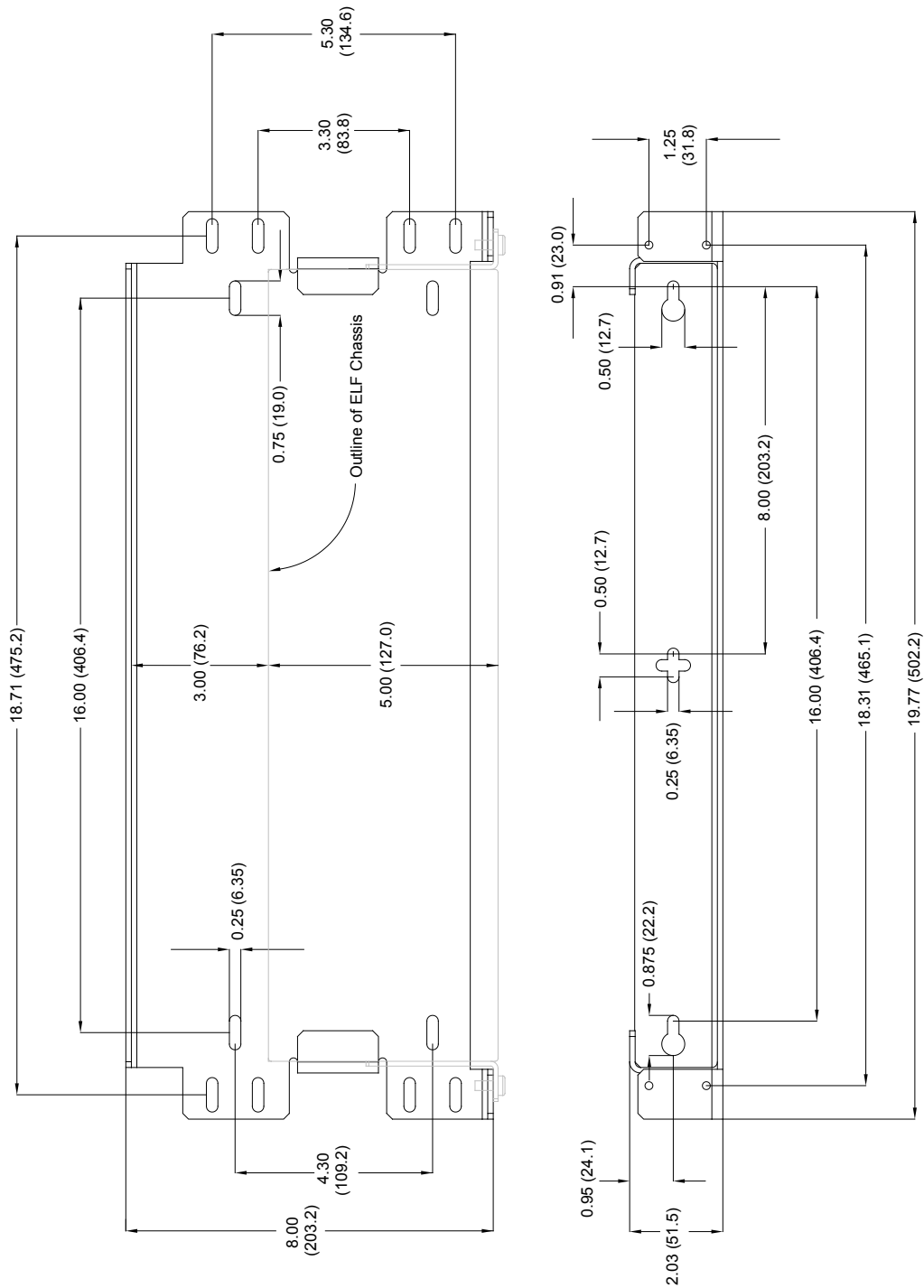

Figure 5 - Wall-Mount ELF Chassis Bracket Dimensions

Typical wall installations are shown in the following illustrations. Telect recommends that the tie bar on the rear of the ELF Chassis be removed when installing in the Wall-Mount ELF Chassis Bracket. Also, when installing rear access ELF modules, Telect recommends including a minimum 2-ft (600-mm) service loop for any cabling or wiring intended for the rear of the ELF module(s). Don't forget to install a ground wire on the ELF Chassis, as shown on Page 7.

ELF System

Copper / Fiber :: ELF Family

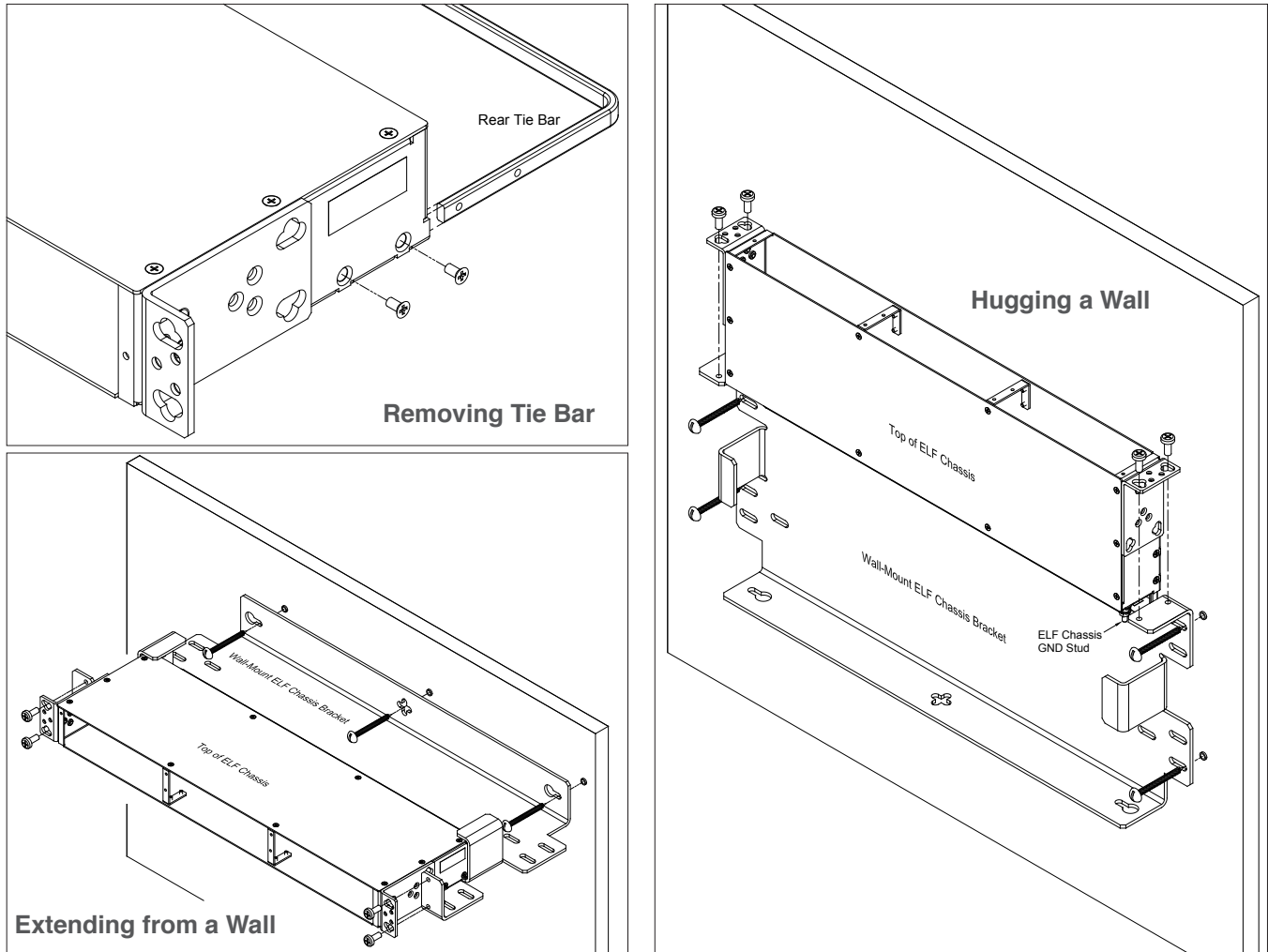

Figure 6 - Wall-Mount ELF Chassis Bracket Installation

ELF System

Copper / Fiber :: ELF Family

1.3.3 ELF Wall Bracket (Model ELF-0000-0600)

Wall-mount bracket for one, total front access ELF module (ELF-3006-1100, ELF-3006-1800, ELF-3004-1800, or ELF -0005-0001). Wall-mounting hardware is not included.

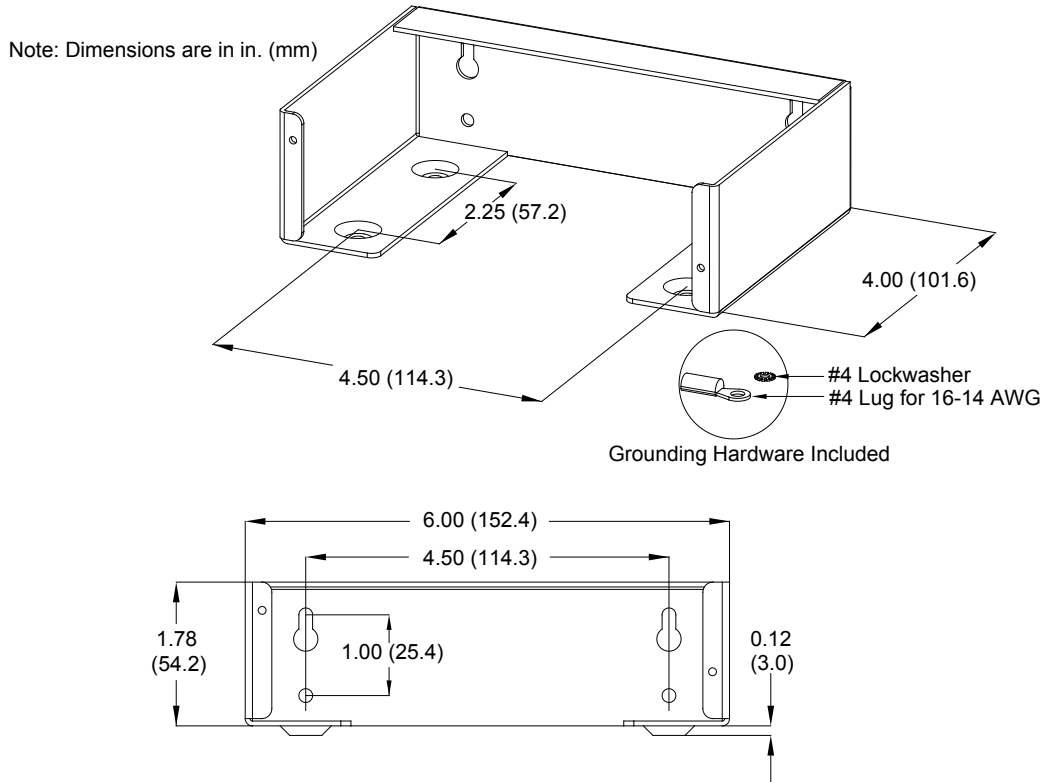

Figure 7 - ELF Wall Bracket Dimensions

The following illustration shows a typical installation.

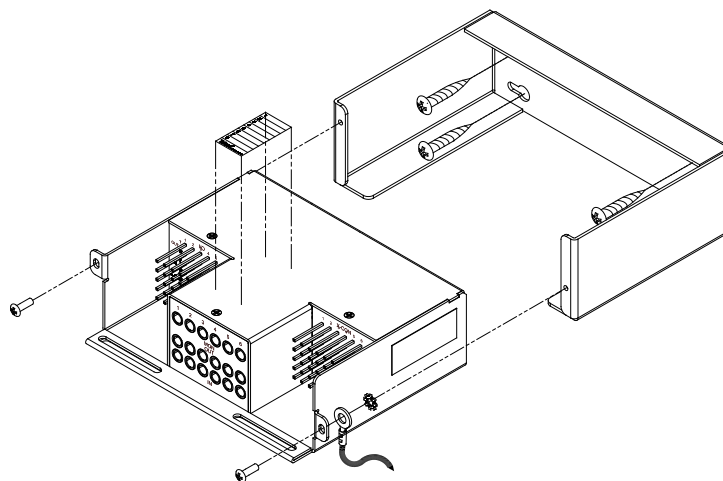

Figure 8 - Typical ELF Wall Bracket Installation

ELF System

Copper / Fiber :: ELF Family

1.3.4 ELF Lockable Wall-Mount Enclosure (Model ELF-0000-0800)

Wall-mount enclosure, designed initially for one fiber ELF module, accommodates any rear-and/or front-access ELF module. Model ELF-000-0800 includes a lockable access door, ideal for co-locations. Wall-mounting and grounding hardware are not included.

The following illustration shows a typical installation.

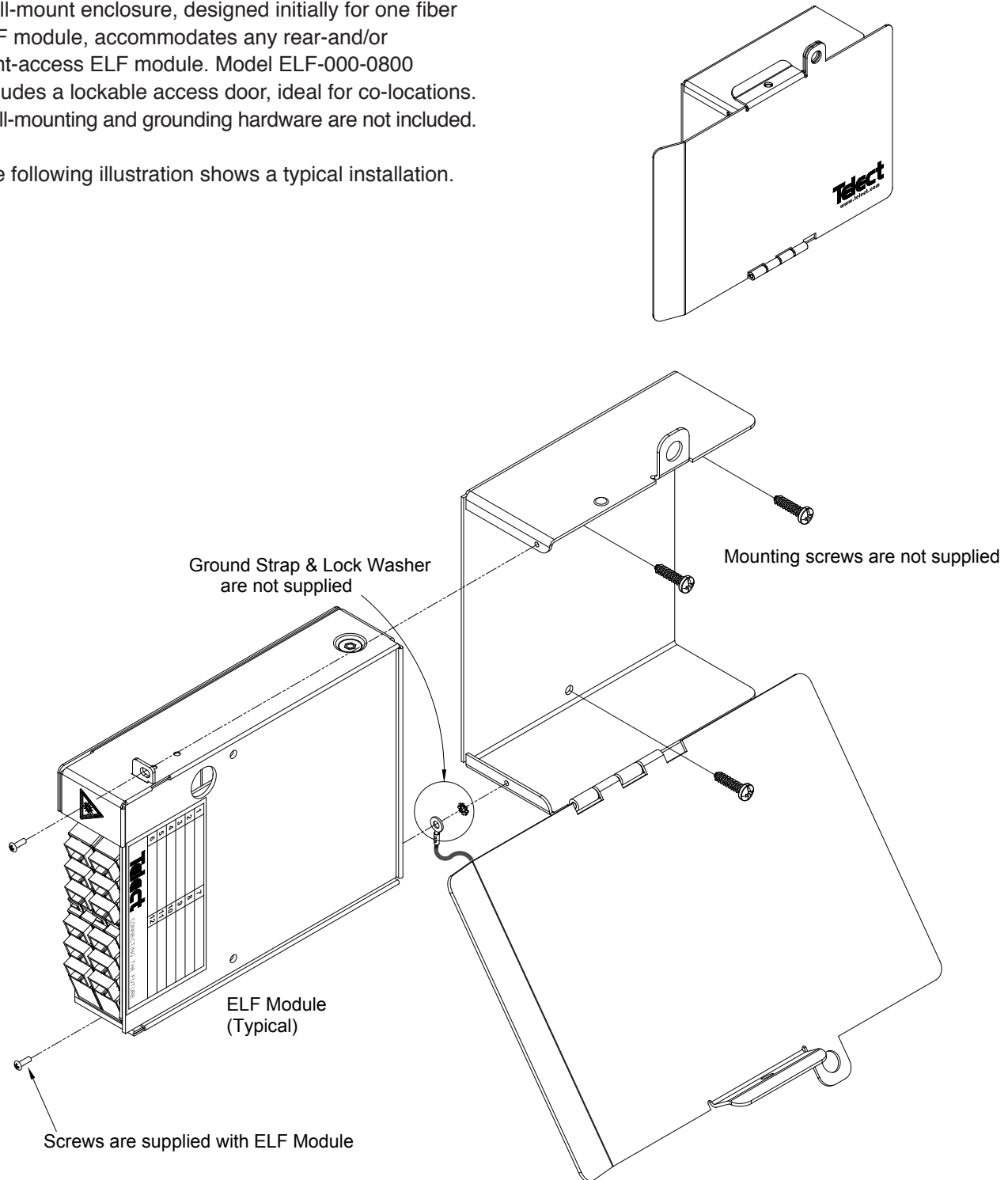

Figure 9 - ELF Lockable Wall-Mount Enclosure

ELF System

Copper / Fiber :: ELF Family

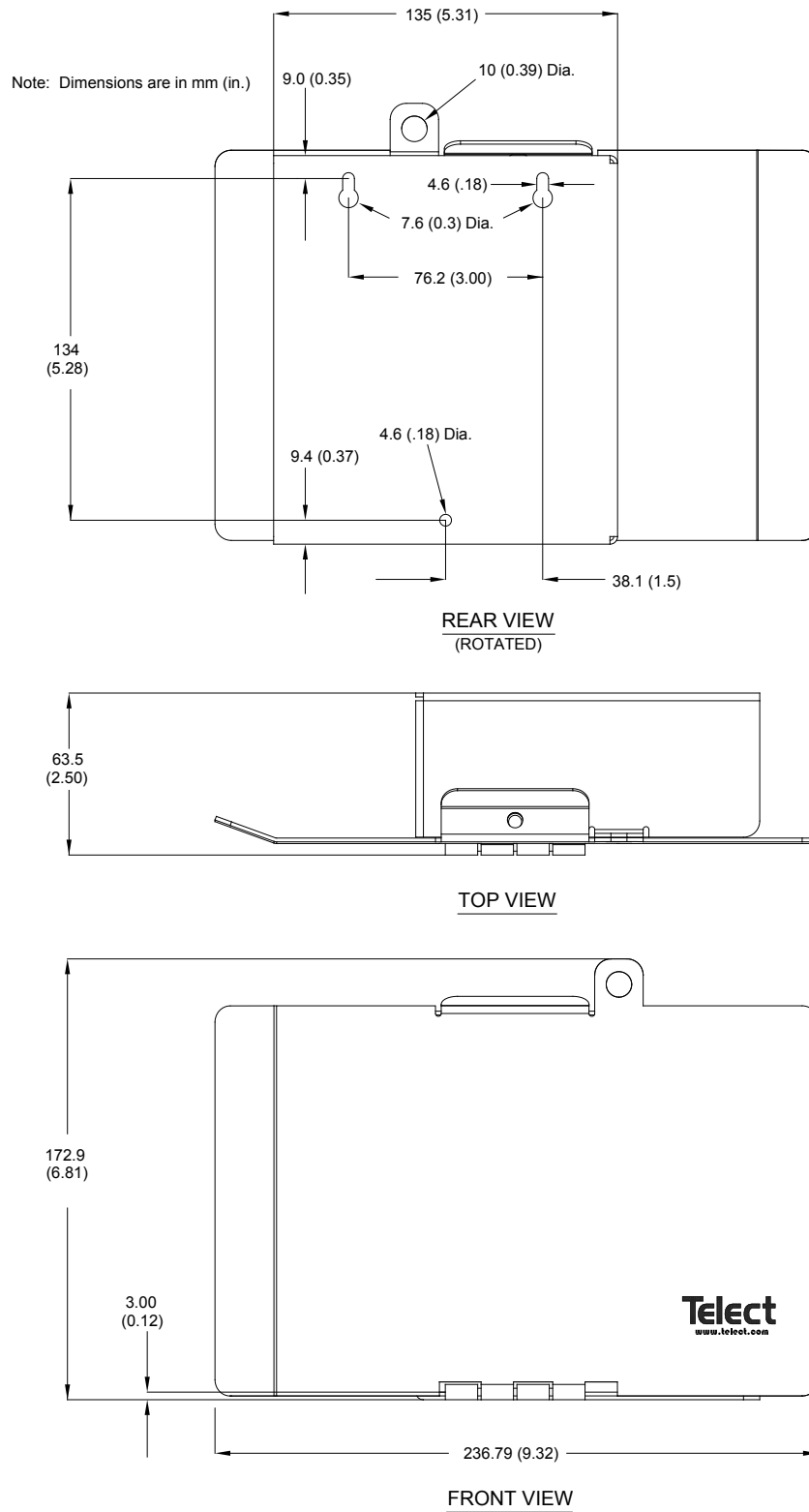

Figure 10 - ELF Lockable Wall-Mount Dimensions

ELF System

Copper / Fiber :: ELF Family

1.4 System-Level Applications

- Fiber Optic Splice/Patch Modules: Manage modest fiber count bundles being delivered to base stations in high-capacity wireless networks.
- DSX-3 Modules: Deliver advanced services outward to the edge of the network, whether wireless or wireline.
- DSX-1 Modules: Gain industry-leading density and options for T1/E1 signal management at the network's edge.
- RJ-TJ Patch Module: In remote HUTs, CEVs, and cabinets, takes T1/Ethernet equipment interface from inaccessible rear connection to front of equipment rack.
- T1 Interconnect RJ45 Modules: Ideal for handoff applications in customer premise environments.

1.5 Installation Considerations



CAUTION

CAUTION! Only qualified technicians may install and maintain this product.



ALERT

ALERT! These instructions presume you have verified that the Telect equipment being installed is compatible with the rest of the system, including power, ground, circuit protection, signal characteristics, equipment from other vendors, and local codes or ordinances.

1.5.1 Location and Space

- The ELF Chassis mounts in a 19 in. or 23 in. equipment rack (EIA or WECO) or inside an equipment cabinet. On an EIA rack, it takes up one RU of space (1RU = 1.75 in.).
- The Wall-Mount ELF Chassis Bracket requires approximately 20 in. (503 mm) by slightly more than 2 in. (52 mm) if a minimum wall “footprint” is desired. If hugging the wall, reserve approximately 20 in. by 8.25 in. (210 mm) of space.
- The ELF Wall Bracket requires approximately 6 in. (155 mm) by approximately 2 in. (45 mm) or 4 in. (102 mm) of wall space, depending on mounting orientation.
- The ELF Wall-Mount Enclosure requires approximately 10 in. (255 mm) by approximately 7 in. (180 mm) of wall space.

1.5.2 Tools and Equipment

- common hand tools
- wire-wrap tools for pinfields
- a chassis ground wire— 14 AWG minimum with ring terminal

Use listed components (UL-recognized, CSA, ETL, TUV agency) and crimping tools.

ELF System

Copper / Fiber :: ELF Family

1.5.3 Inspection

Compare the contents of the ELF shipping container(s) with the packing list. Call Telect if you are missing anything.

Telect is not liable for shipping damage.

If the shipping container is damaged, keep it for the carrier's inspection. Notify the carrier and call Telect at 1-509-926-6000.

Keep the container until you have checked equipment operation. If you experience any kind of problem, call Telect's Customer Service Department. Use the original, undamaged container if you are instructed to return the ELF equipment to Telect.

1.5.4 Technical Support (USA)

Please read and understand all instructions before starting installation. If you have questions, contact Telect Technical Support at support@telect.com or call 1.509.926.6000.

When you receive the equipment, carefully unpack it and compare it to the packaging list. Please report any defective or missing parts to Telect Quality at quality@telect.com or call 1.509.926.6000.

Telect is not liable for transit damaged. If the product is damaged, please report it to the carrier and contact Telect Quality.

1.6 Specifications

Table 1 - DS1 Electrical

	E1 Specification	T1 Specification
Return Loss	12 dB 51 kHz to 102 kHz 18 dB 102 kHz to 2048 kHz 14 dB 2048 kHz to 3073 kHz	26 dB 772 kHz
Insertion Loss	0.5 dB at bit rate (2.048 Mbps)	0.5 dB at bit rate (1.544 Mbps)
Monitor Level	-20 dB ± 1.5 dB at bit rate (2.048 Mbps)	-20 dB ± 1.5 dB at bit rate (1.544 Mbps)
Contact Resistance	<0.01 Ohms	
Characteristic Impedance	100/120 Ohms	
Adjacent Channel Crosstalk	-60 dB at bit rate (2.048 Mbps)	-60 dB at bit rate (1.544 Mbps)
Interchannel Crosstalk	-60 dB at bit rate (2.048 Mbps)	-60 dB at bit rate (1.544 Mbps)

ELF System

Copper / Fiber :: ELF Family

Table 2 - DS3 Electrical

	Specification
Return Loss	<-26 dB at DS3, STS-1, and E3 signal rates
Insertion Loss	<1.00 dB at DS3 signal rates for modules with one monitor network
Monitor Level	21 dB \pm 1.5 dB below signal level
Contact Resistance	<0.01 Ohms
Characteristic Impedance	75 Ohms

Table 3 - Fiber Optics

	Specification
Return Loss	>55 dB
Insertion Loss	<0.5 dB
Mode	Single
Bandpass	1310/1550 \pm 20 nm

ELF System

Copper / Fiber :: ELF Family

This page was intentionally left blank

ELF System

Copper / Fiber :: ELF Family

Chapter 2: ELF DS1 Modules

Telect offers five DSX-1 and two DNI-1 ELF Modules:

- All three ELF DSX-1 8-Termination Modules feature network element RJ45, BNC, or wirewrap connections on the rear and Telect's Bantam patch/monitor jacks and wire-wrap crossconnections on the front.
- Both ELF DSX-1 6-Termination Modules are total front access modules. Wire-wrap network element, wire-wrap cross-connections, and Bantam patch/monitor jacks are all on the front.
- Both ELF DNI-1 4-Circuit Modules contain RJ48C termination on the front along with 4 sets of Bantam patch/monitor jacks for the NE interconnections. One DNI-1 module is total front access with all Bantam interconnections between RJ48C NE-1/NE-2 terminations; the other module interconnects four NE-2 RJ48C termination on the front with wire-wrapped NE-1 termination on the rear.

2.1 ELF 8-Termination DSX-1, Wire-Wrap I/O (Model ELF-1008-1100)

Eight-circuit network element I/O wire-wrap pinfield on the rear and corresponding cross-connect pinfield and Bantam-style patch and monitor jacks on the front. Both pinfields provide individual shield grounds for each set of jacks. Screws for mounting module to an ELF chassis or lockable wall-mount enclosure are included.

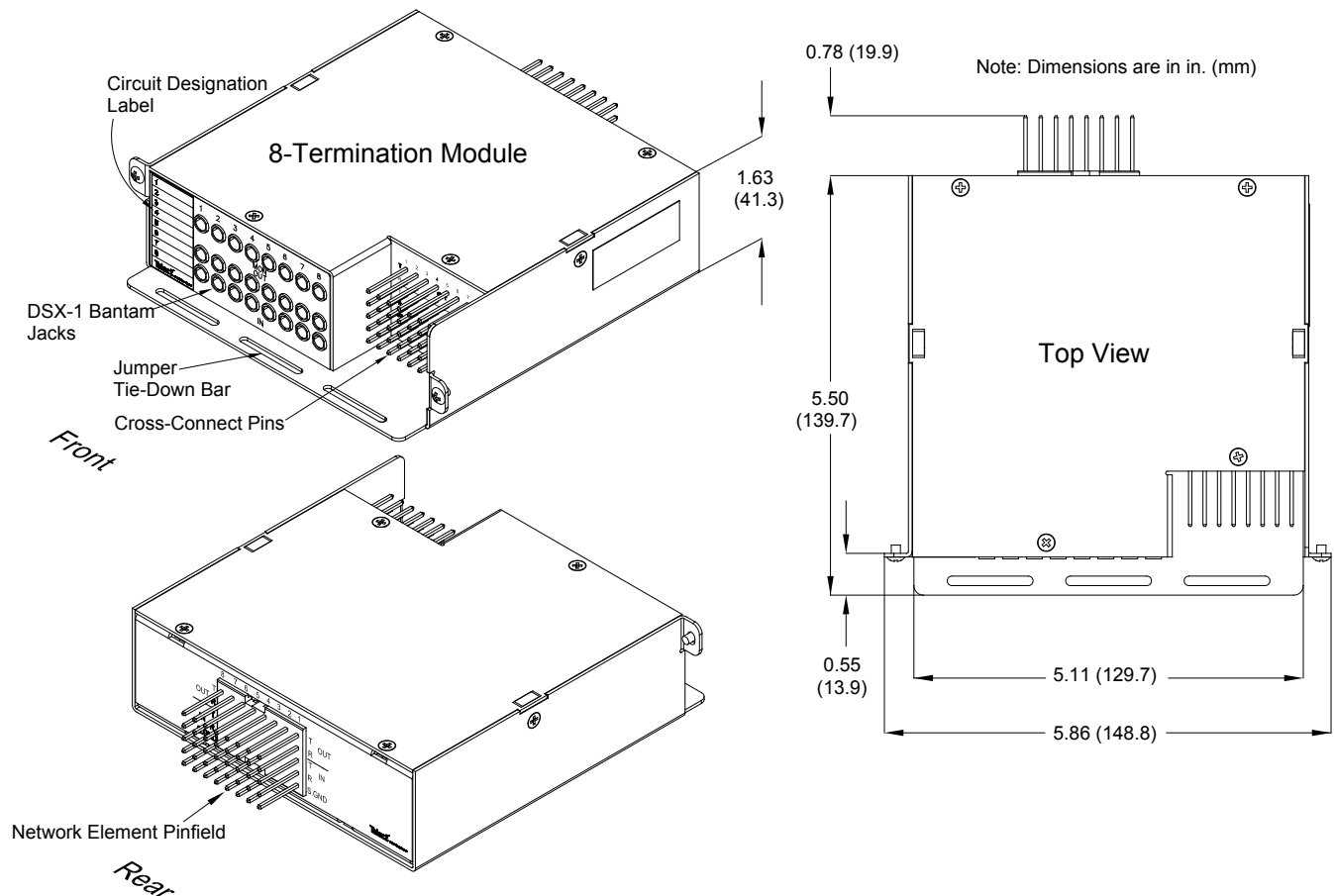

ELF System

Copper / Fiber :: ELF Family

RESISTOR VALUE = 475 ohm

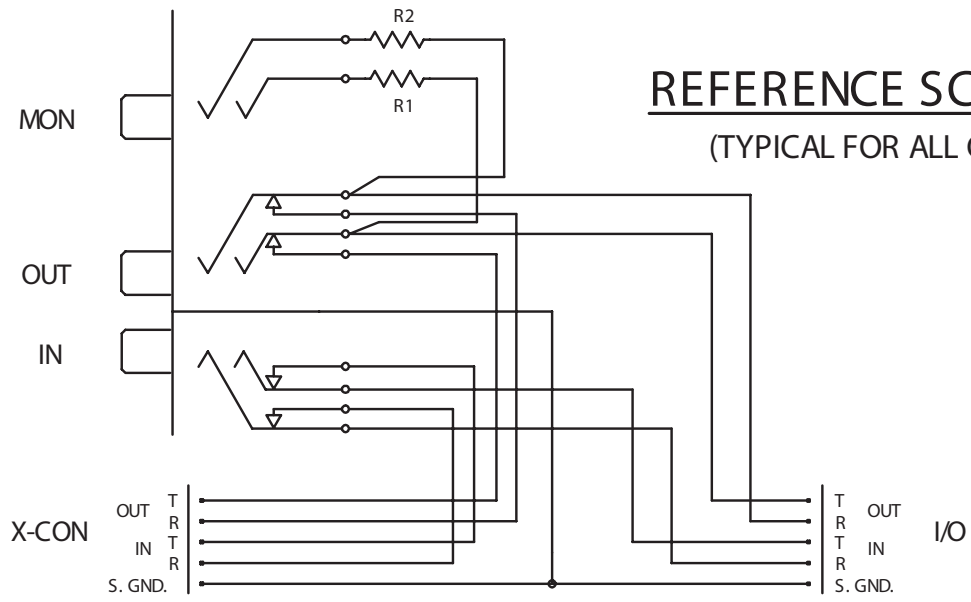

Figure 12 - Model ELF-1008-1100 Reference Schematic

ELF System

Copper / Fiber :: ELF Family

2.2 ELF 8-Termination DSX-1, BNC I/O (Model ELF-1008-1200)

Eight-circuit network element BNCs on the rear and corresponding cross-connect pinfield and Bantam-style patch and monitor jacks on the front. Pinfield provides shield grounds for each circuit. Screws for mounting module to an ELF chassis or lockable wall-mount enclosure are included.

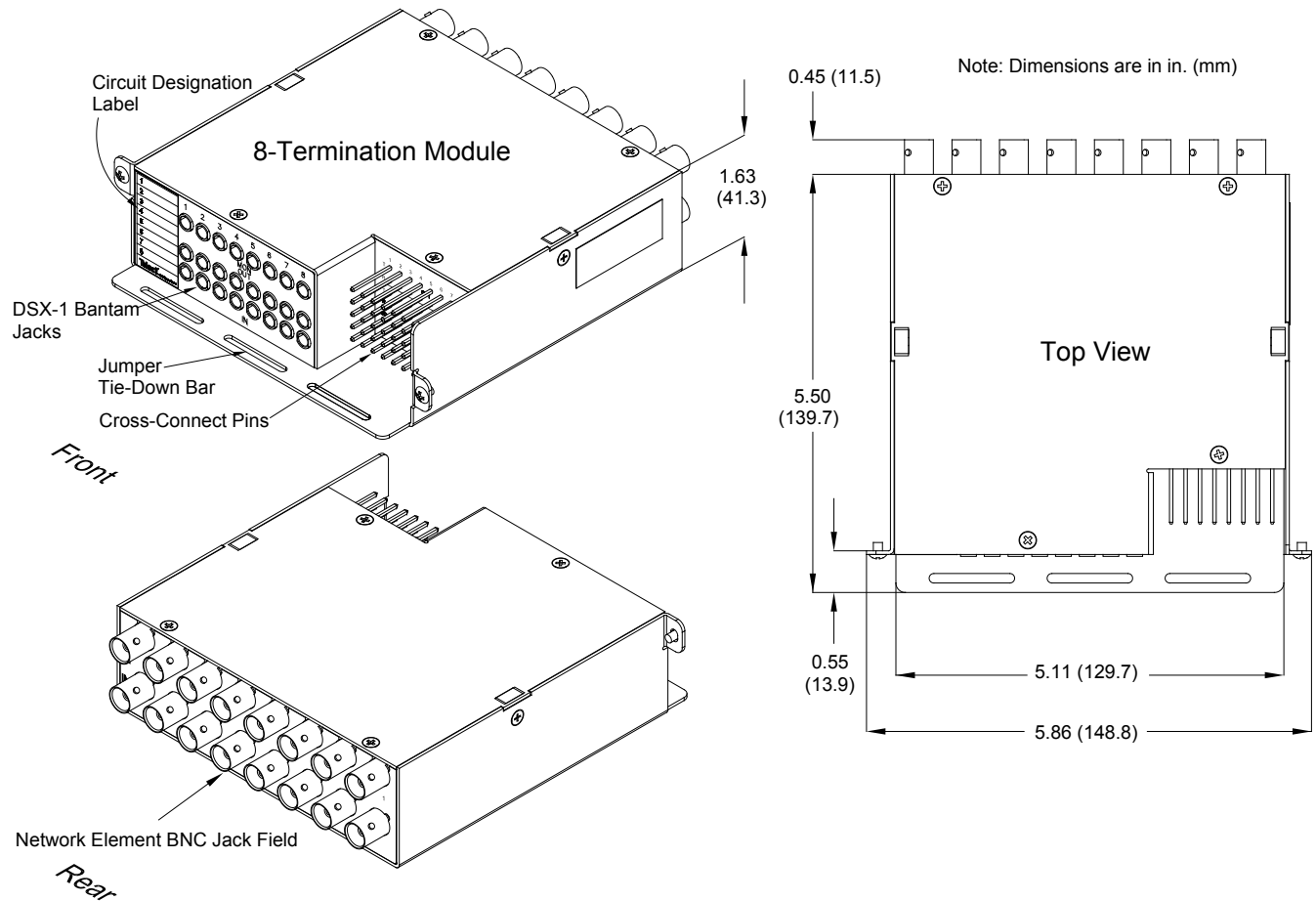

Figure 13 - Model ELF-1008-1200 Dimensions

ELF System

Copper / Fiber :: ELF Family

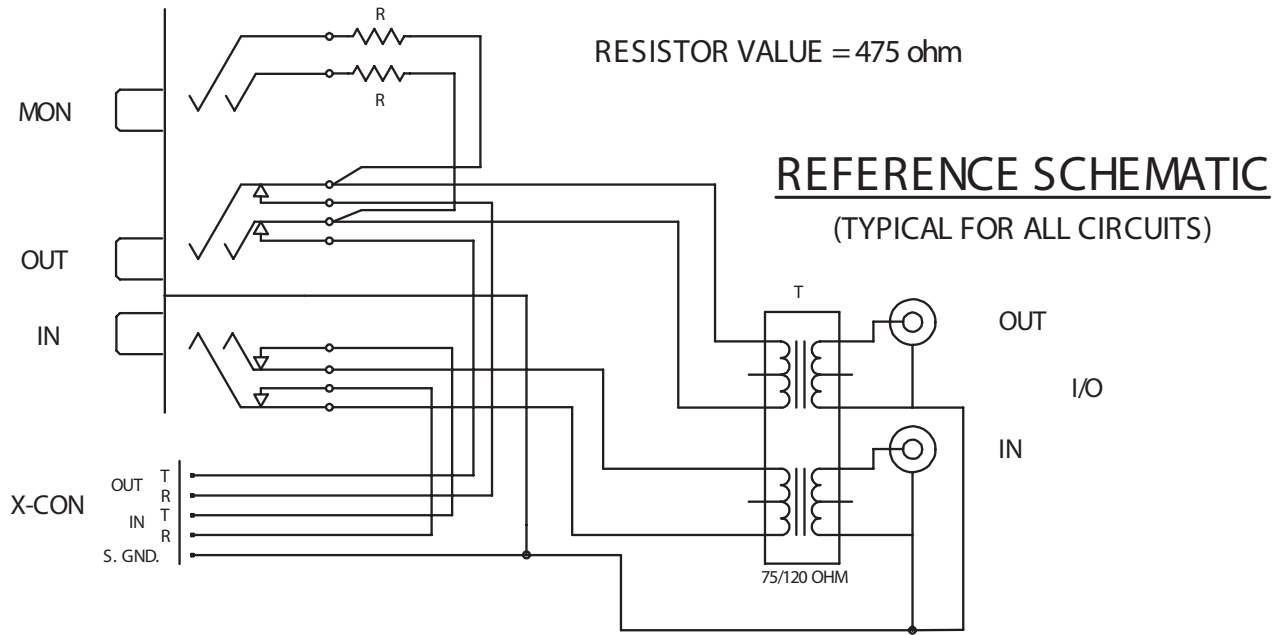

Figure 14 - Model ELF-1008-1200 Reference Schematic

ELF System

Copper / Fiber :: ELF Family

2.3 ELF 8-Termination DSX-1, RJ48C I/O (Model ELF-1008-1800)

Eight-circuit network element RJ48Cs on the rear and corresponding cross-connect pinfield and Bantam-style patch and monitor jacks on the front. Pinfield provides shield grounds for each circuit. Screws for mounting module to an ELF chassis or lockable wall-mount enclosure are included.

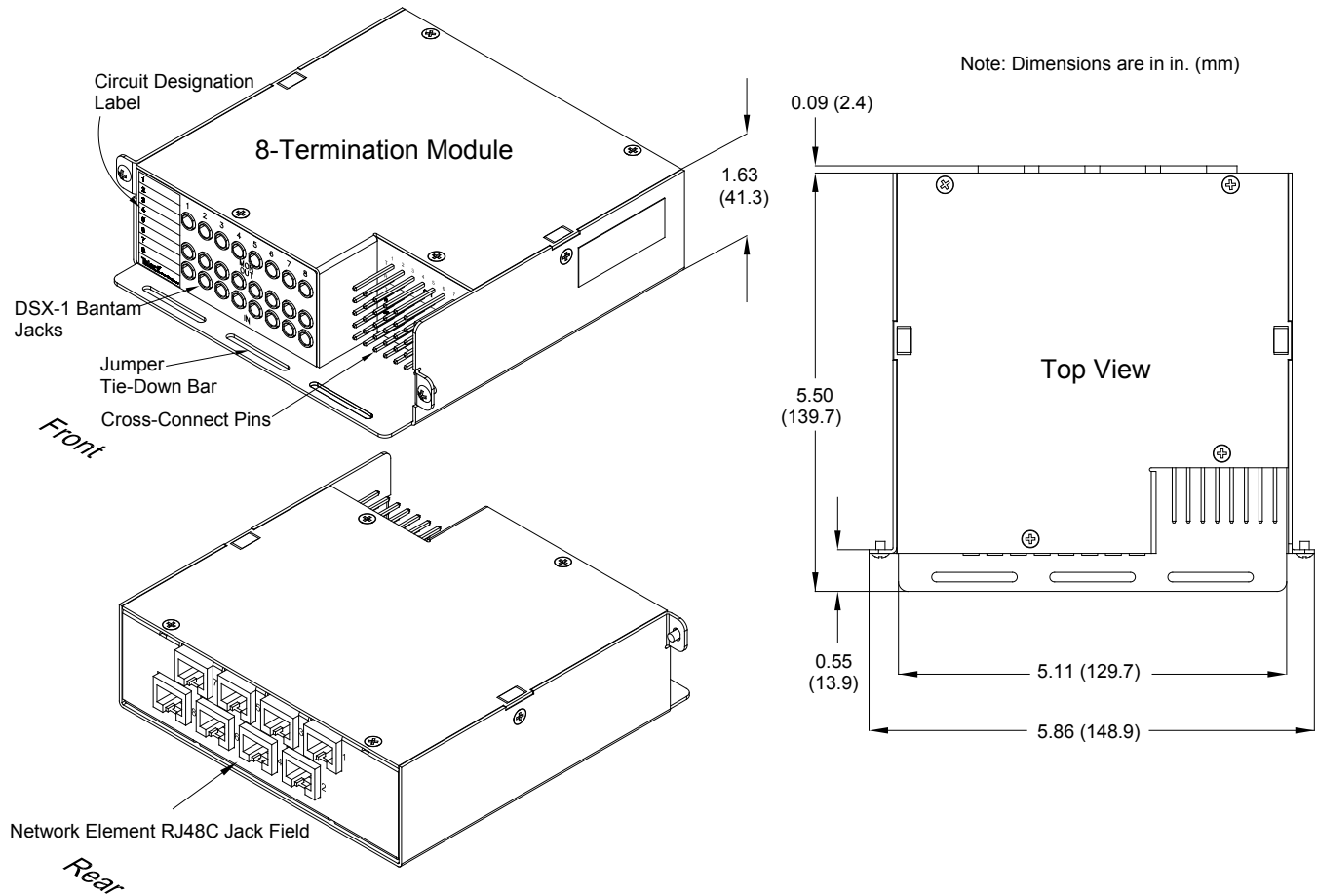

Figure 15 - Model ELF-1008-1800 Dimensions

ELF System

Copper / Fiber :: ELF Family

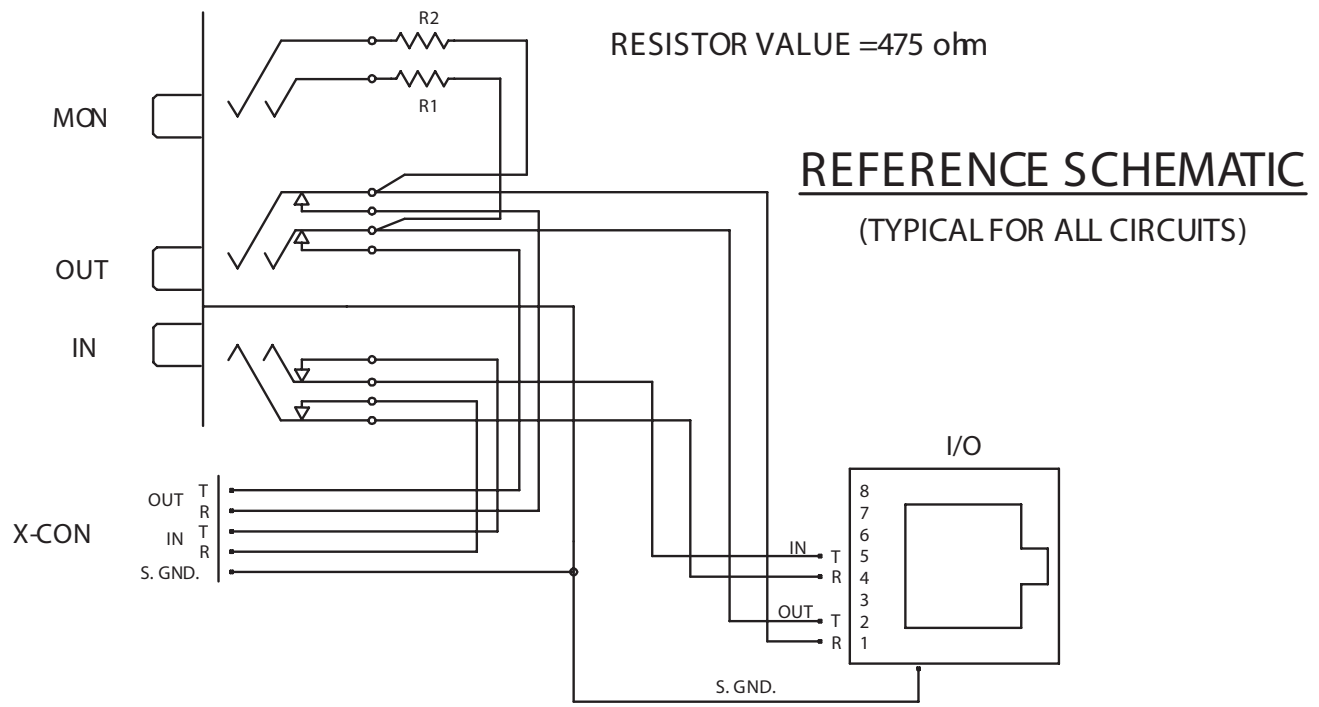

Figure 16 - Model ELF-1008-1800 Reference Schematic

ELF System

Copper / Fiber :: ELF Family

2.4 ELF 6-Termination DSX-1, Wire-Wrap I/O (Model ELF-3006-1100)

Six-circuit NE I/O and cross-connect pinfields and Bantam-style patch and monitor jacks are all on the front. Both pinfields provide individual shield grounds for each set of jacks. Screws for mounting module to an ELF chassis, wall-mount bracket, or lockable wall-mount enclosure are included.

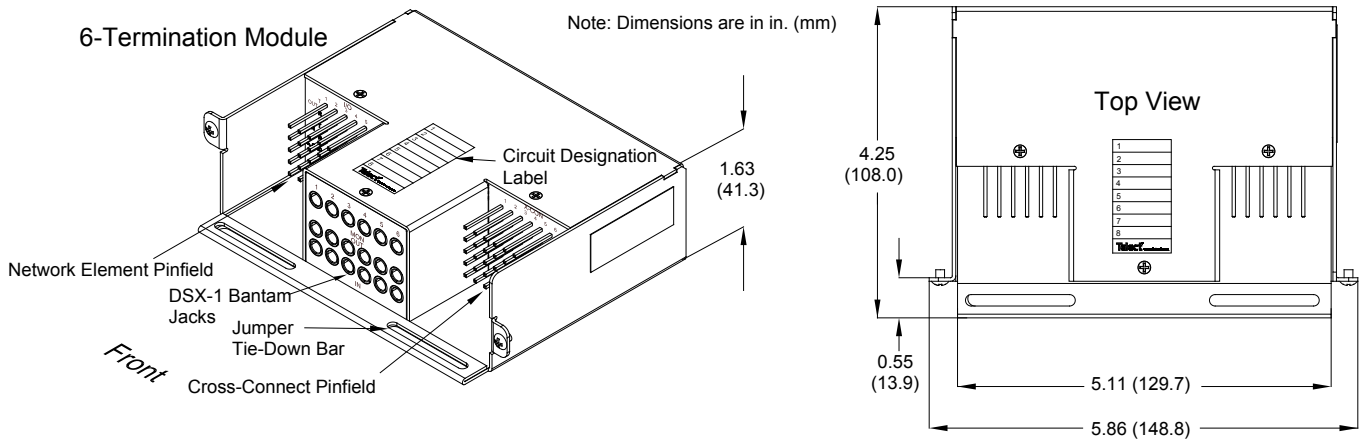

Figure 17 - Model ELF-3006-1100 Dimensions

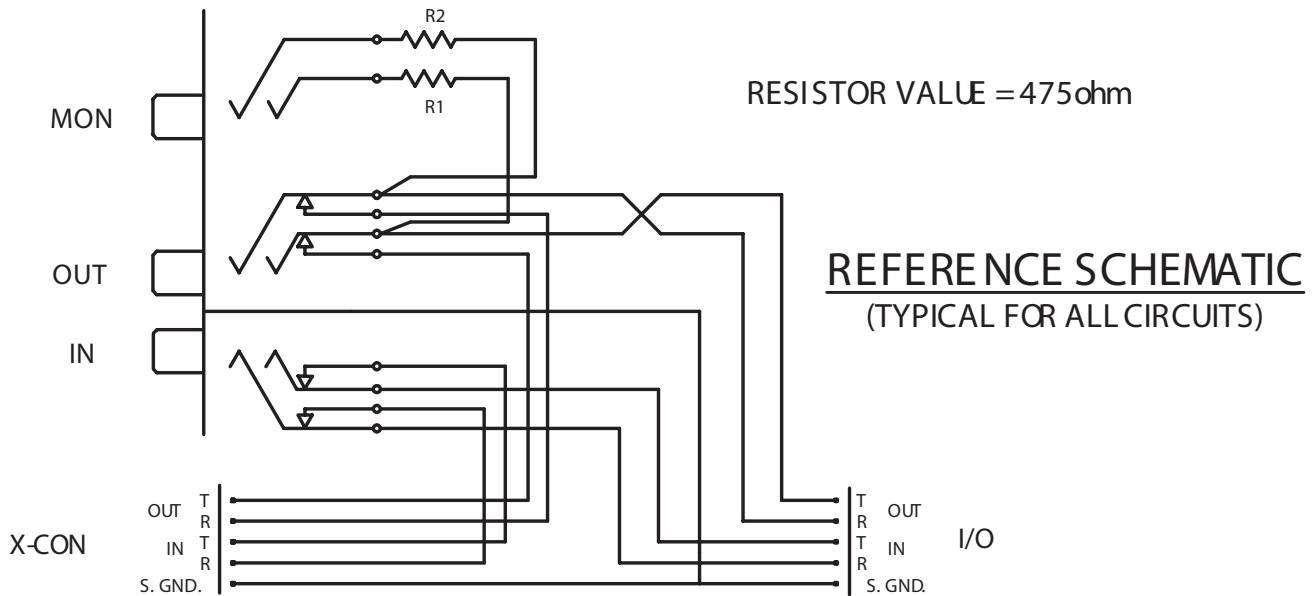

Figure 18 - Model ELF-3006-1100 Reference Schematic

ELF System

Copper / Fiber :: ELF Family

2.5 ELF 6-Termination DSX-1, RJ48C I/O (Model ELF-3006-1800)

Six-circuit network element and cross-connect RJ48Cs, along with Bantam-style patch and monitor jacks, are all on the front. Screws for mounting module to an ELF chassis, wall-mount bracket, or lockable wall-mount enclosure are included.

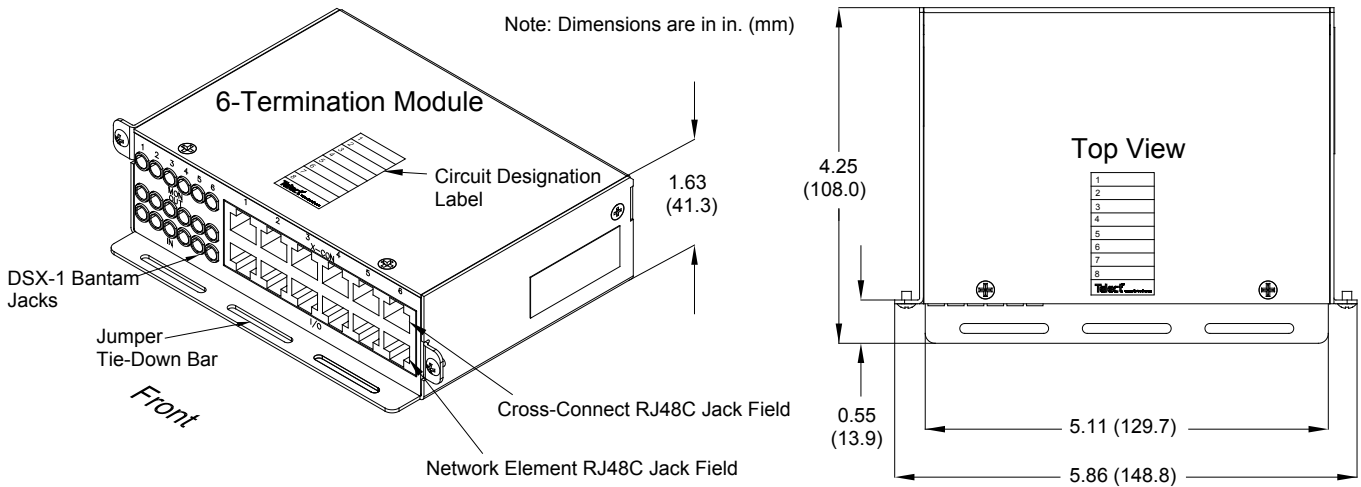

Figure 19 - Model ELF-3006-1800 Dimensions

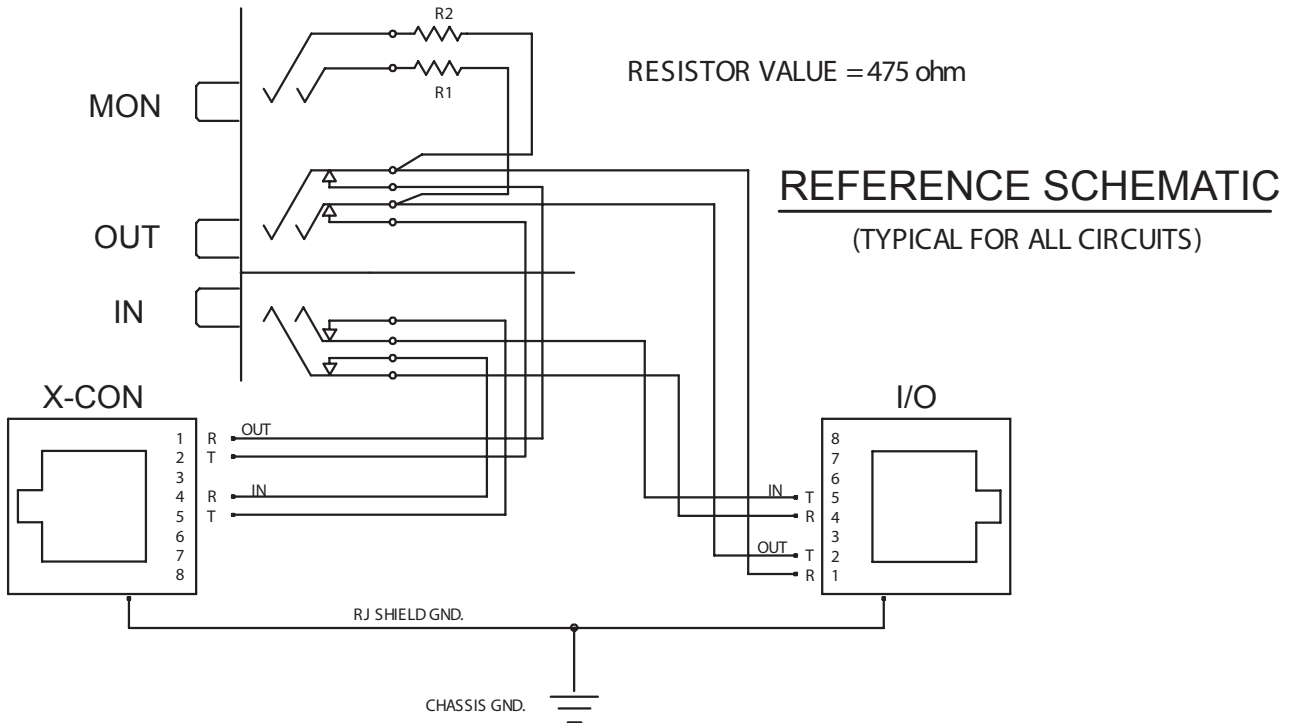

Figure 20 - Model ELF-3006-1800 Reference Schematic

ELF System

Copper / Fiber :: ELF Family

2.6 ELF 4-Circuit DNI-1, Wire-Wrap I/O to RJ48C I/O (Model ELF-9704-1119)

This ELF DNI-1 4-Circuit Module contains 4, NE-1 wire-wrap termination on the rear. 4, NE-2 RJ48C termination are on the front along with 4 sets of Bantam-style patch and monitor jacks for interconnections and testing. Shields for all cable connectors are connected internally to chassis ground along with a shield ground pin for the wire-wrapped NE-1 cable. Screws for mounting module to an ELF chassis or lockable wall-mount enclosure are included.

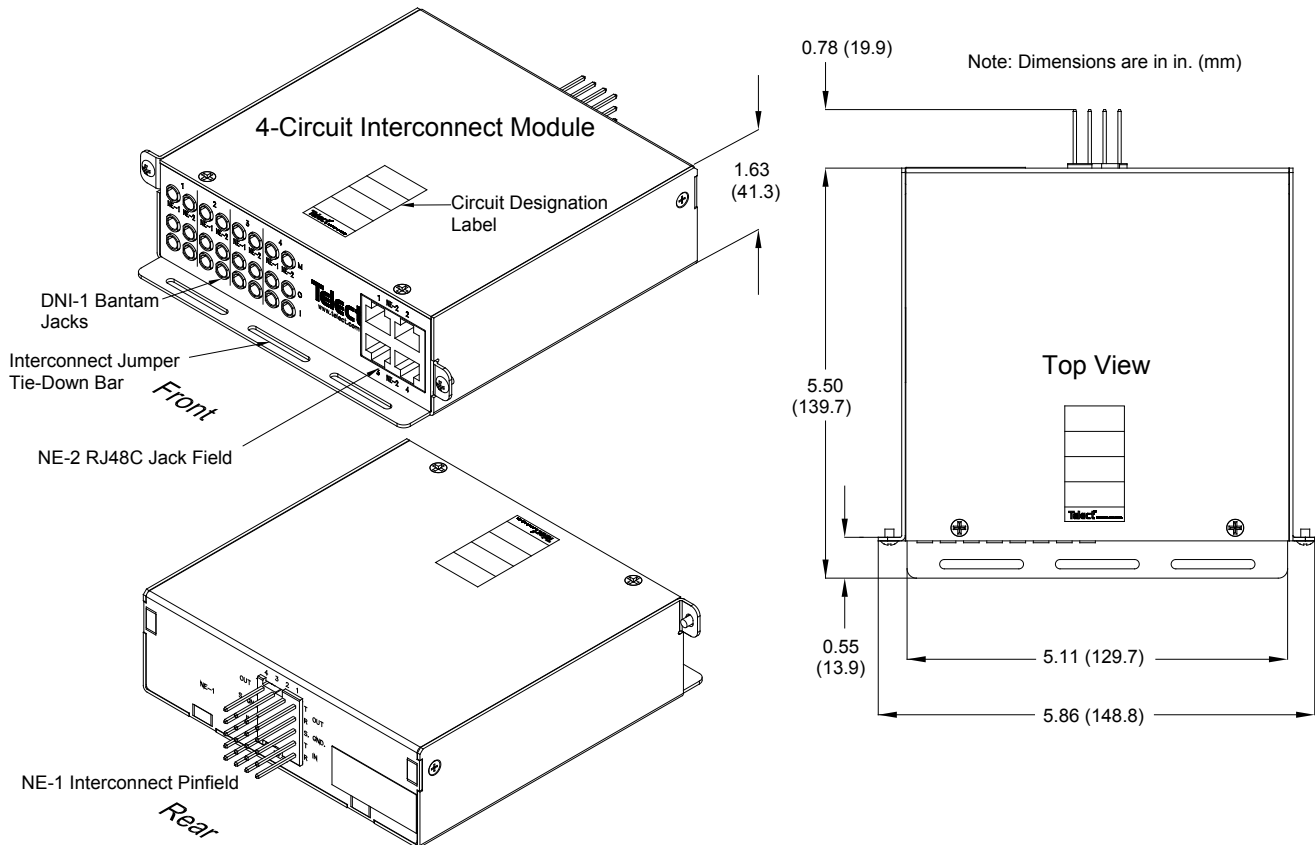

Figure 21 - Model ELF-9704-1119 Dimensions

ELF System

Copper / Fiber :: ELF Family

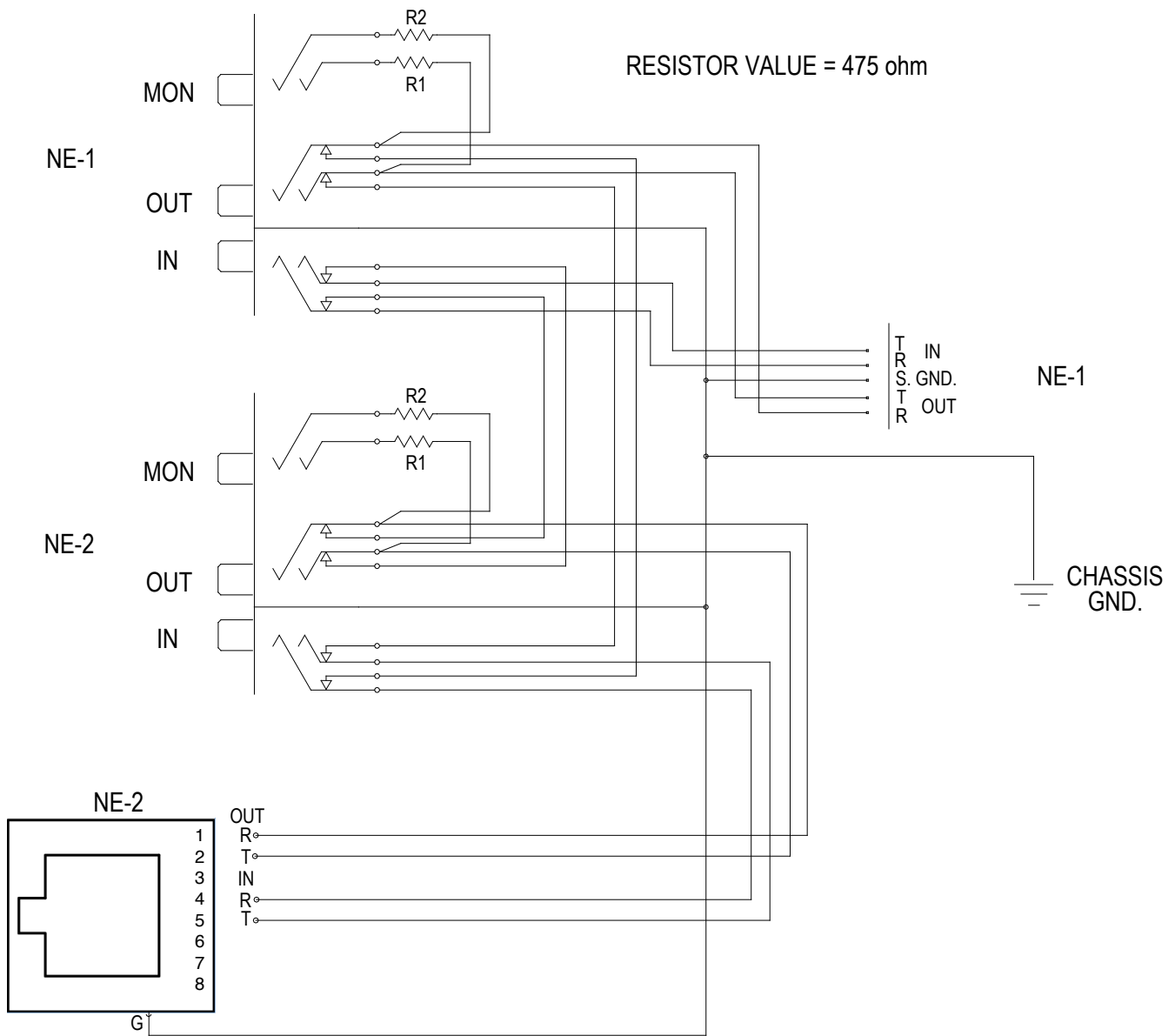

Figure 22 - Model ELF-9704-1119 Reference Schematic

ELF System

Copper / Fiber :: ELF Family

2.7 ELF 4-Circuit DNI-1, RJ48C I/O to RJ48C I/O (Model ELF-3004-1800)

The ELF DNI-1 4-Circuit Total Front Access Module contains 4, NE-1 and 4, NE-2 RJ48C terminations on the front along with 4 sets of Bantam-style patch and monitor jacks for interconnections and testing. Shields for all cable connectors are connected internally to chassis ground. Screws for mounting module to an ELF chassis, wall-mount bracket, or lockable wallmount enclosure are included.

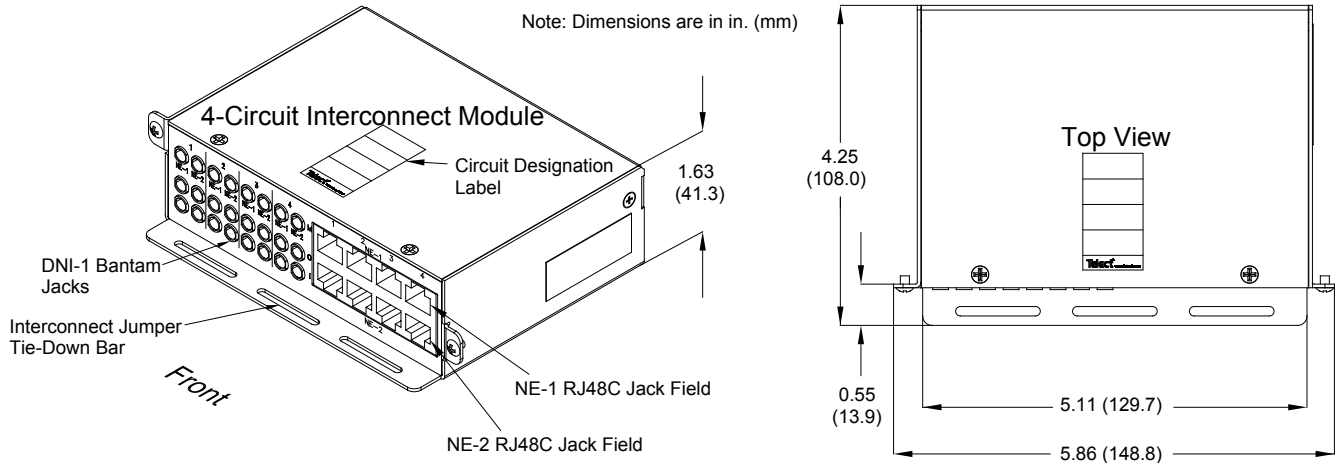

Figure 23 - Model ELF-3004-1800 Dimensions

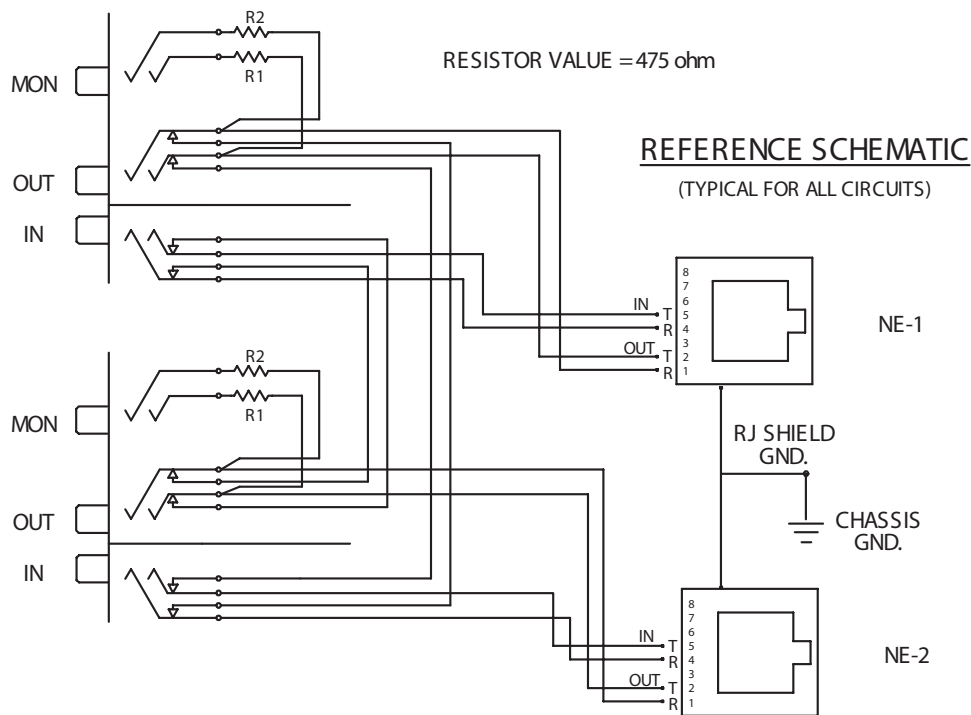

Figure 24 - Model ELF-3004-1800 Reference Schematic

ELF System

Copper / Fiber :: ELF Family

This page intentionally left blank

ELF System

Copper / Fiber :: ELF Family

Chapter 3: ELF DSX Modules

Telect offers two DSX-3 ELF Modules. Both feature 6-port mini-WECOs for temporary I/O and cross-connect patching, testing, and monitoring, along with BNC connectors for normal NE I/O and cross-connections:

- ELF 2-Termination DSX-3 (Model ELF-3206-1200) has the NE BNCs on the rear, and
- ELF 1-Termination DSX-3 (Model ELF-3206-1900) is total front access (TFA).

Both modules fit the ELF chassis and Lockable Wall-Mount Enclosure. Mounting screws for installing on the chassis or enclosure are included.

3.1 ELF 2-Termination DSX-3, Rear BNC I/O (Model ELF-3206-1200)

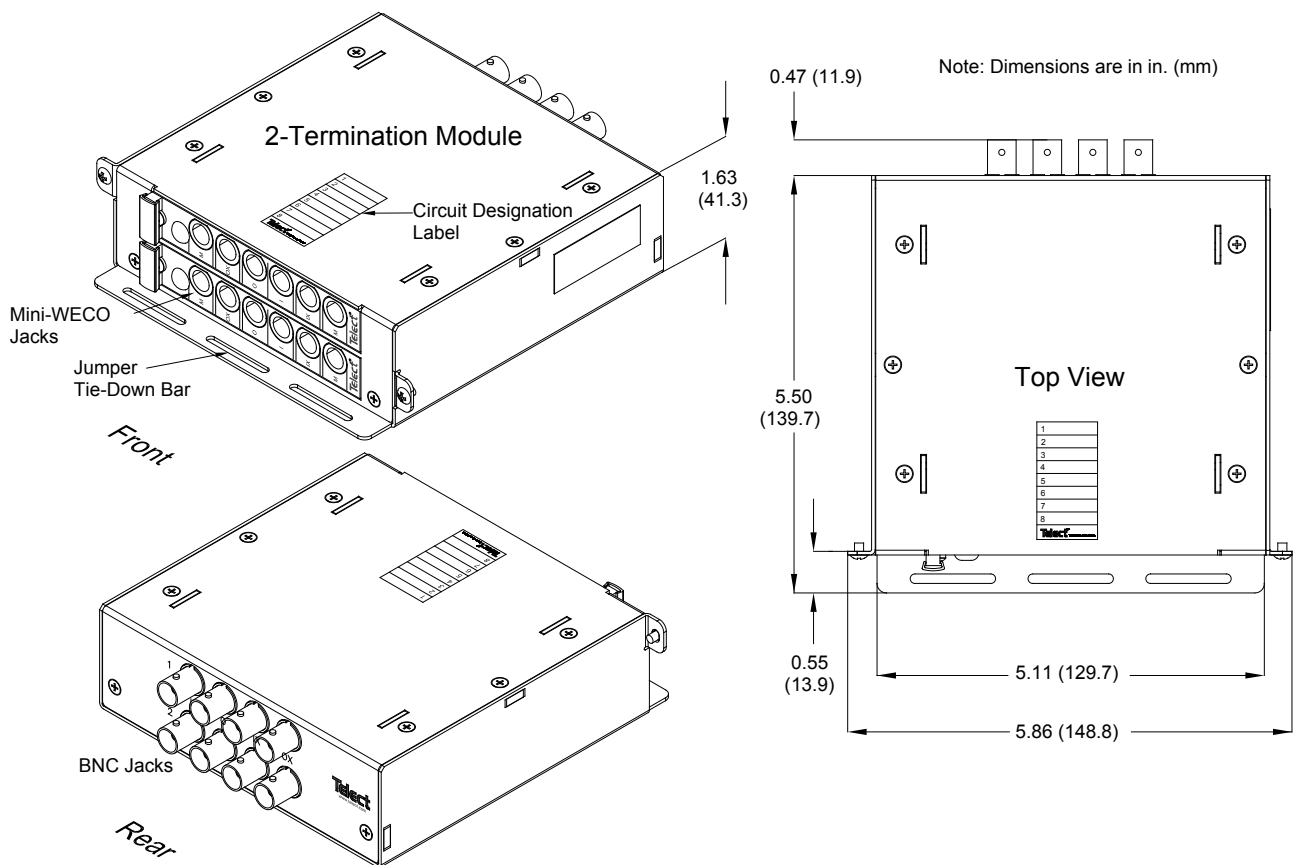
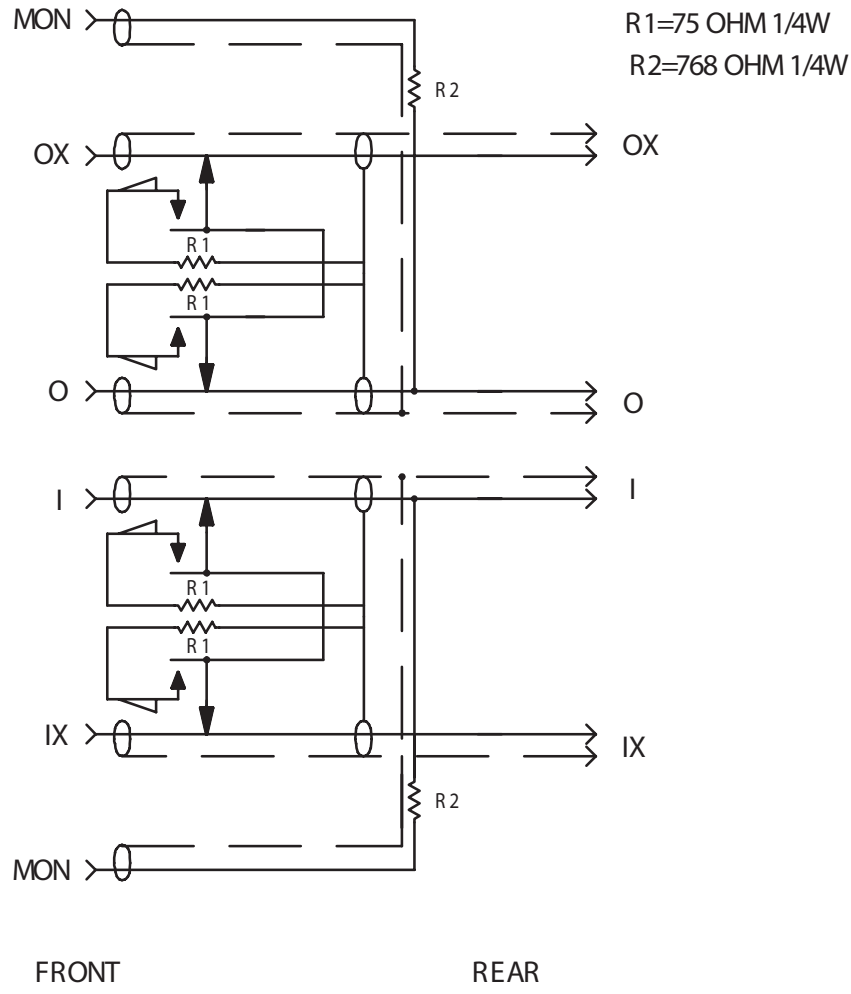

Figure 25 - Model ELF-3206-1200 Dimensions

ELF System

Copper / Fiber :: ELF Family



REFERENCE SCHEMATIC

Figure 26 - Model ELF-3206-1200 Reference Schematic

ELF System

Copper / Fiber :: ELF Family

3.2 ELF 1-Termination DSX-3, TFA BNC I/O (Model ELF-3206-1900)

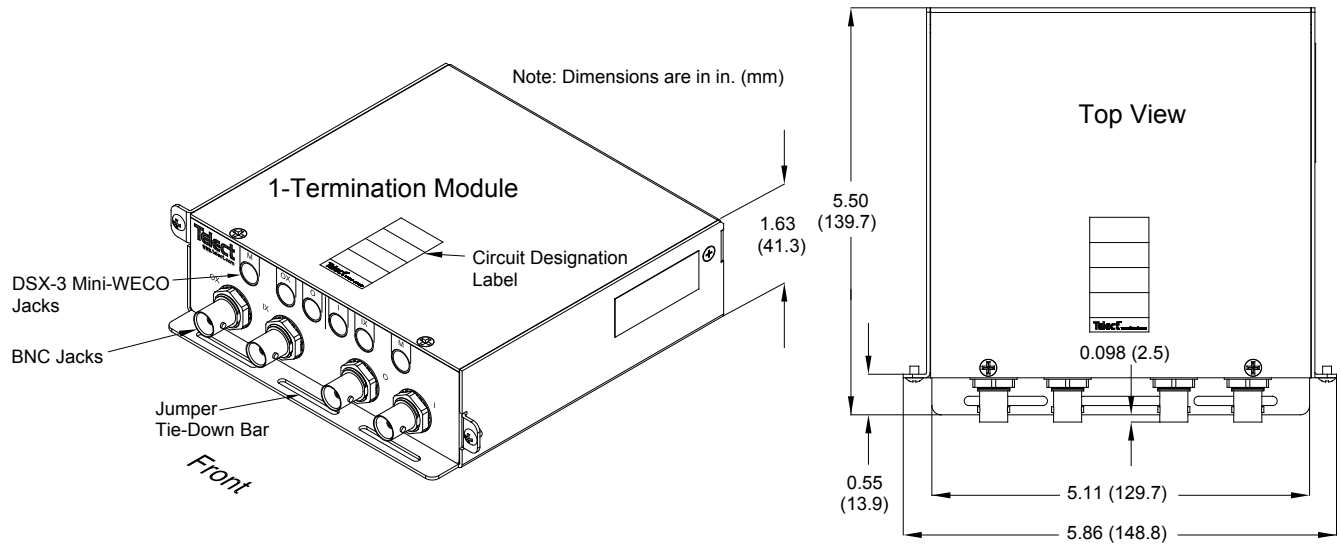
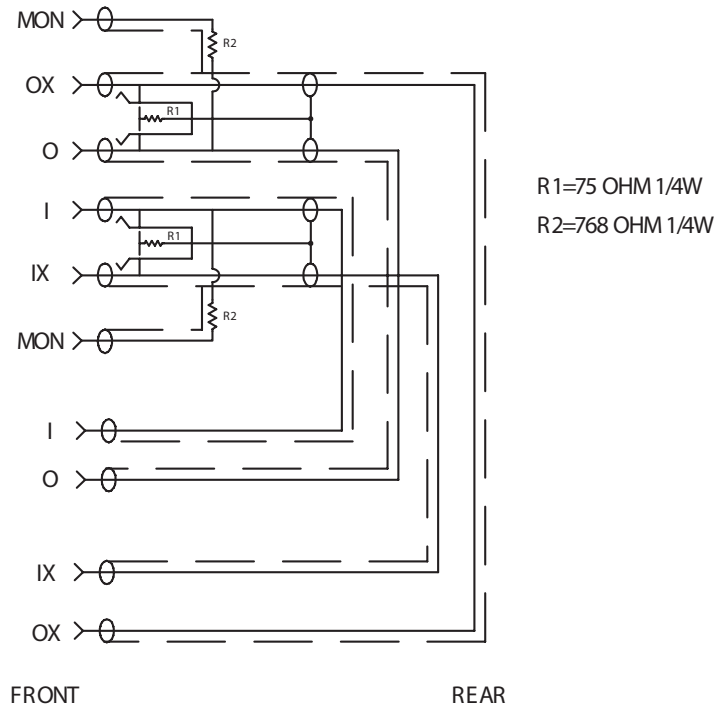

Figure 27 - Model ELF-3206-1900 Dimensions



REFERENCE SCHEMATIC

Figure 28 - Model ELF-3206-1900 Reference Schematic

ELF System

Copper / Fiber :: ELF Family

This page intentionally left blank.

Chapter 4: ELF Fiber Modules

Telect manufactures two Fiber ELF platforms for patching, and patching with splicing:

- ELF Fiber Patch (Models ELF-PC12-SC00, ELF-PC12-FC00, ELF-PC12-SA00, and ELF-PC24-LC00)
- ELF Fiber Splice/Patch (Models ELF-SP12-SCPT, ELF-SP12-FCPT, and ELF-SP12-SAPT)

All modules are available with either 12, SC/UPC, FC/UPC, SC/APC, or 24 LC/APC adapters. All modules fit the ELF chassis and lockable wall-mount enclosure. Mounting screws for installing on the chassis or enclosure are included. Telect supplies dust covers for all open fiber adapters.

4.1 ELF Fiber Patch Modules (Model Series ELF-PC12-XX00)

The following illustration shows an ELF-PC12-SC00.

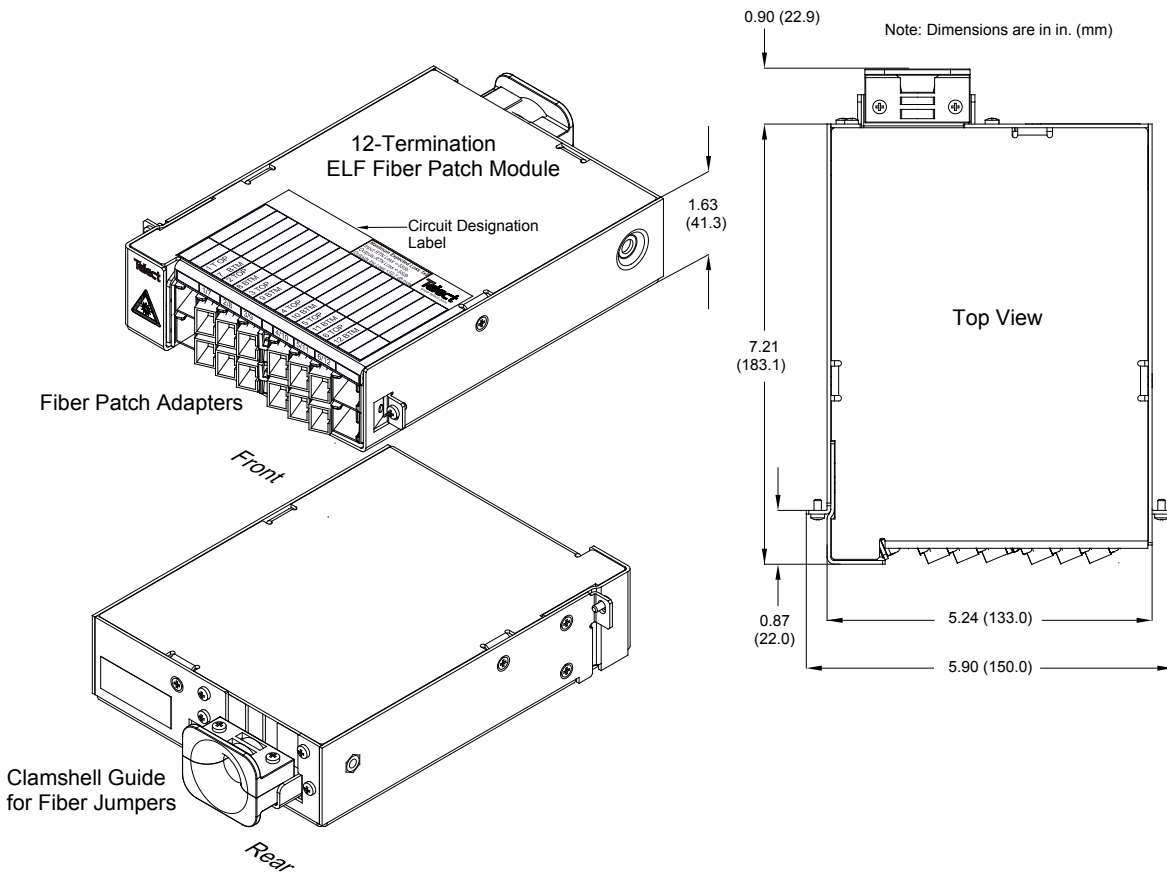

Figure 29 - ELF-PC12-SC00

You can purchase Fiber Patch Modules with factory-installed 2-mm fiber jumpers, as shown below

ELF System

Copper / Fiber :: ELF Family

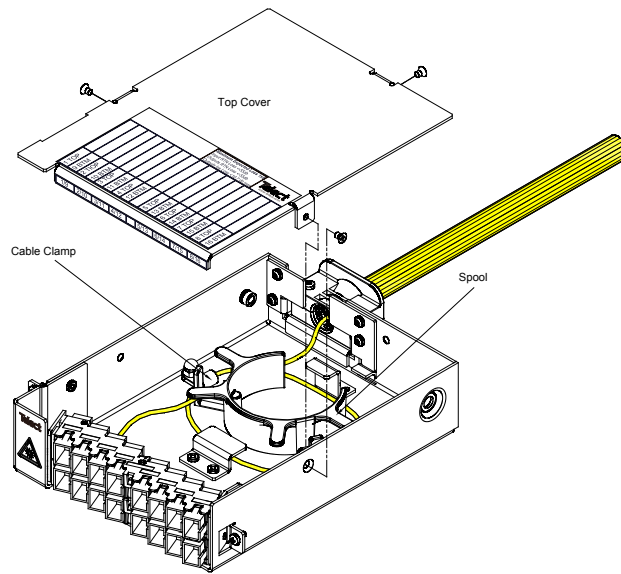

Figure 30 - ELF Patch Module (Model ELF-PC12-SCxx, Typical Cabling)

4.2 ELF Fiber Splice/Patch Modules (Model Series ELF-SP12-XXPT)

The following illustration shows an ELF-SP12-XXPT.

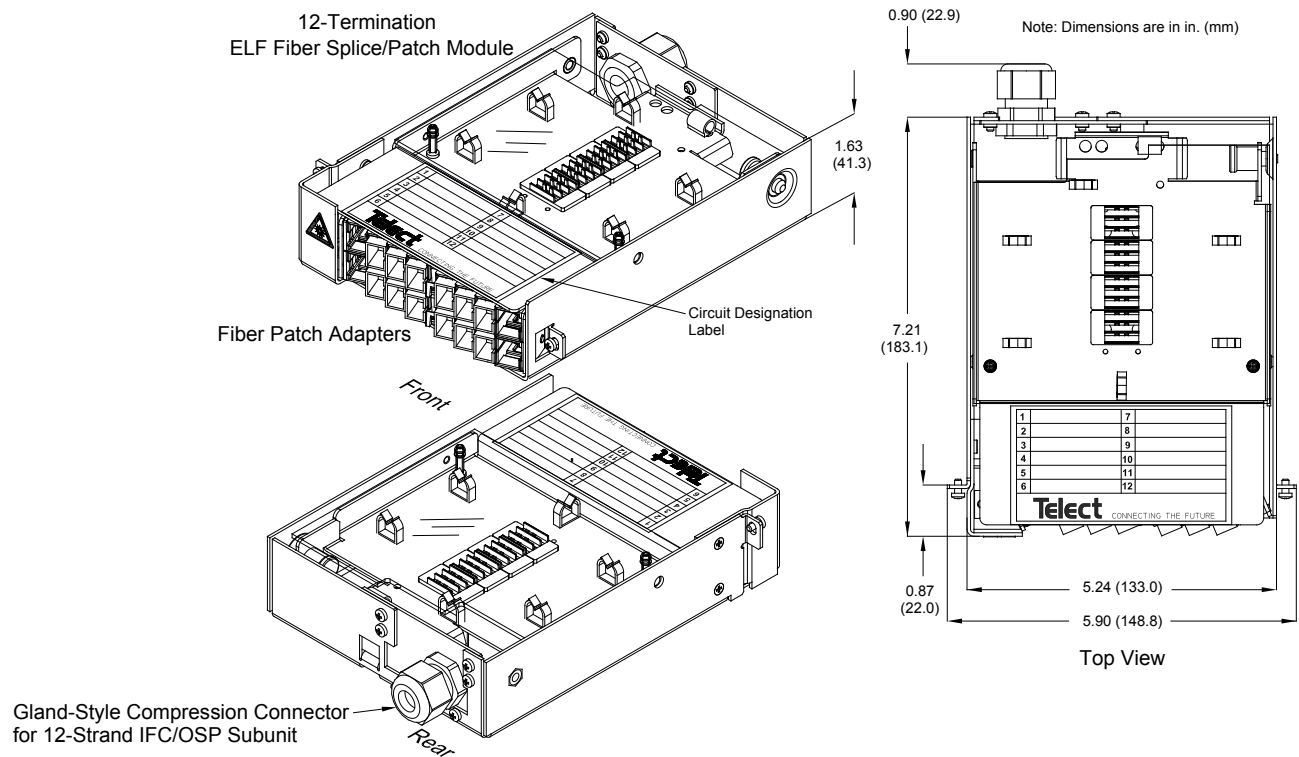

Figure 31 - Model Series ELF-SP12-XXPT Parts & Dimensions

ELF System

Copper / Fiber :: ELF Family

The module consists of a splice cassette mounted atop a subunit entrance compartment. (See the following illustrations.) The splice cassette is covered by a transparent plastic cover.

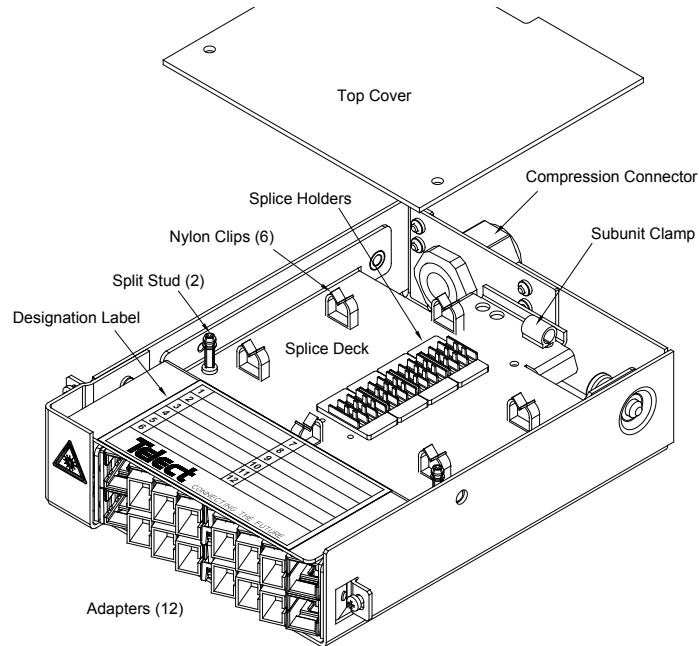

Figure 32 - Splice Cassette

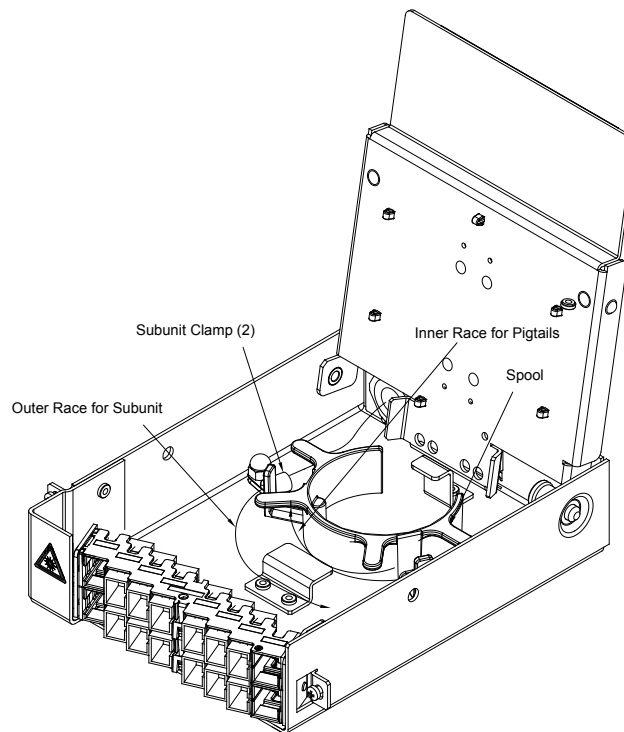

Figure 33 - Subunit Entrance Compartment

ELF System

Copper / Fiber :: ELF Family

You can purchase Fiber Splice/Patch Modules with 12 factory-installed 900 μm pigtailed for splicing to fiber strands from an incoming IFC/OSP subunit. The opposite ends of factory-installed pigtailed are terminated on the rear face of the fiber adapter at the front of the module.

The illustration on the right shows a finished installation with 12 fiber strands (Model ELF-SP12-SCPT).

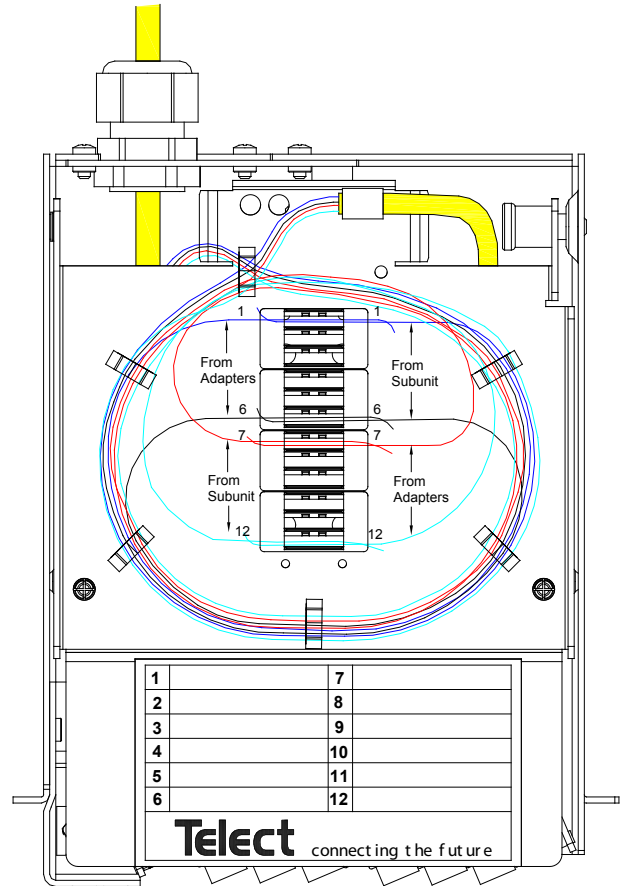

Figure 34 - ELF Splice/Patch Module
(Model ELF-SP12-SCPT
Typical Cabling)

Chapter 5: ELF Multi-Purpose Modules

Telect manufactures three multi-purpose signal manager modules for RJ45C and pin-block signals. All signal manager modules are straight feed-through:

- The ELF RJ45C to RJ45C Patch Module (Model ELF-9716-1900) contains 16 RJ45C connectors on the rear which interconnect with 16 RJ45C connectors on the front. The module fits the ELF chassis and lockable wall-mount enclosure.
- The ELF RJ45 to IDC Patch Module (Model ELF-9716-1700) contains 16 RJ45 connectors on the front which interconnect to T568A-coded IDC punch-down blocks for 100-Ohm cable on the rear. The module fits the ELF chassis and lockable wall-mount enclosure.
- The ELF 12 x 4 Alarm Pin Block Module (Model ELF-0005-0001) is a bulkhead pin block primarily intended for interconnecting alarm signals. ELF-0005-0001 fits the ELF chassis, the wall-mount bracket, and the lockable-wall-mount enclosure.

Mounting screws for installing on the chassis, bracket, or enclosure are included.

ELF System

Copper / Fiber :: ELF Family

5.1 ELF RJ45C to RJ45C Patch Module (Model ELF-9716-1900)

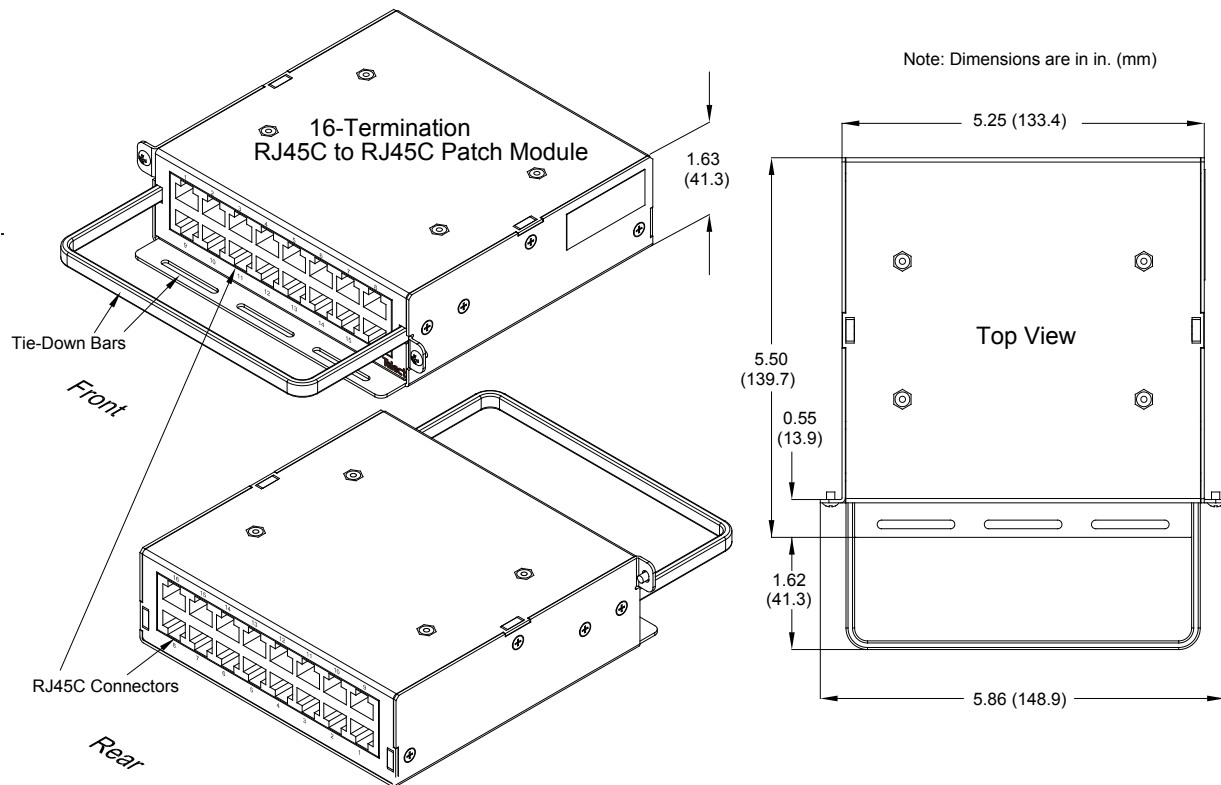

Figure 35 - Model ELF-9716-1900 Parts & Dimensions

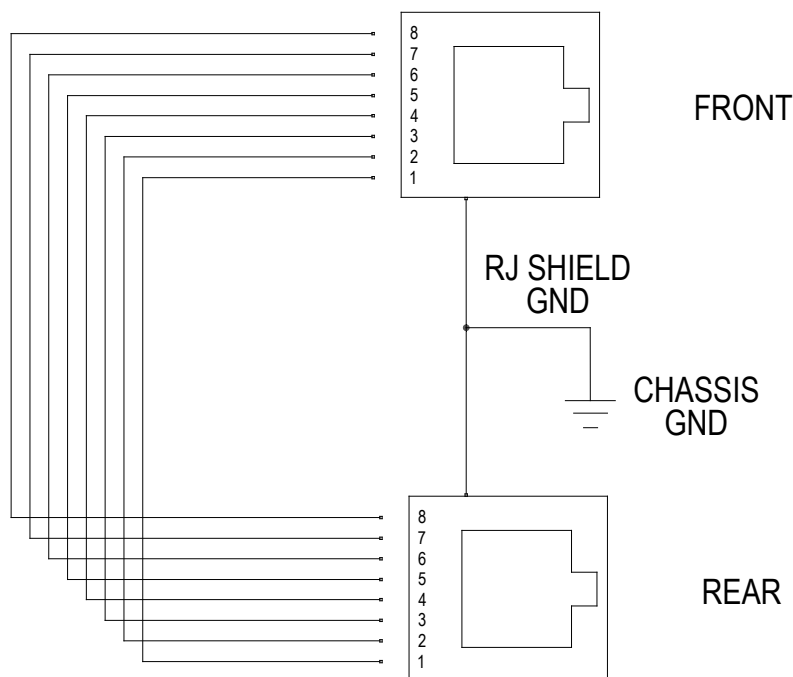

Figure 36 - Model ELF-9716-1900 Schematic

ELF System

Copper / Fiber :: ELF Family

5.2 ELF RJ45-IDC Patch Module (Model ELF-9716-1700)

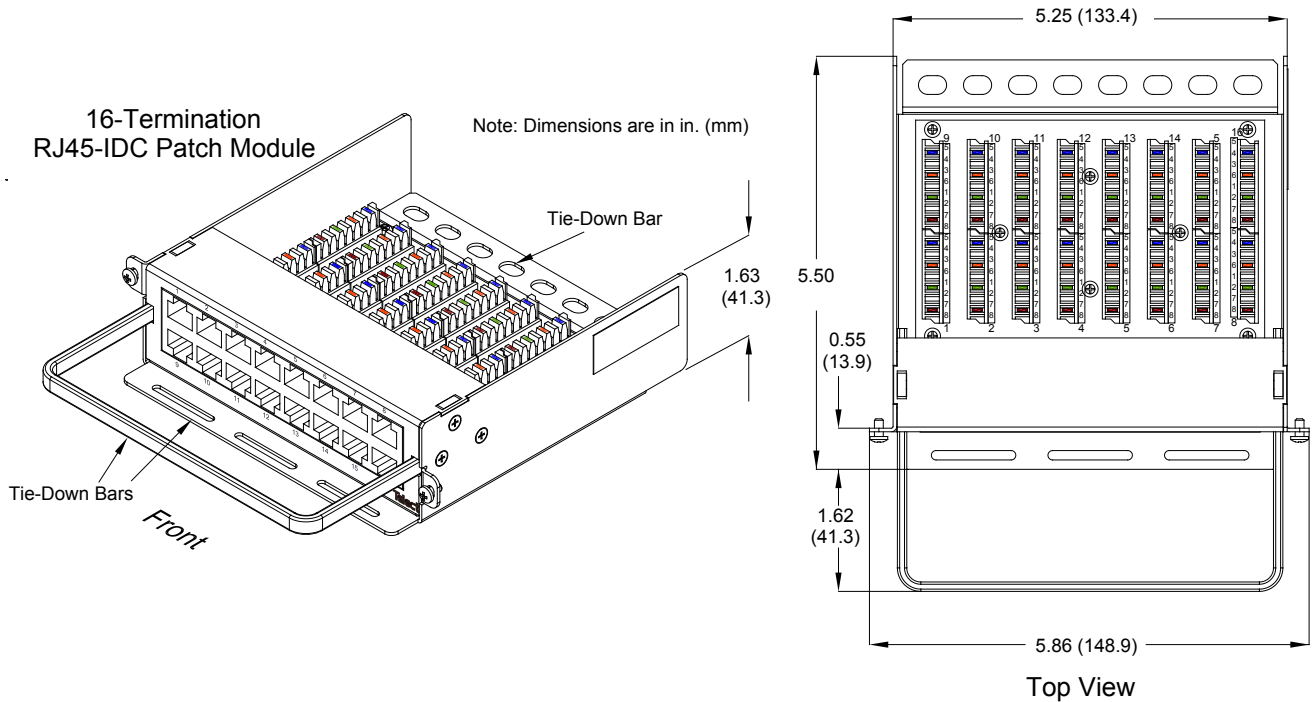

Figure 37 - Model ELF-9716-1700 Parts & Dimensions

A schematic illustration is shown on the right and a finished cable and wiring illustration is shown in the following illustration.

Please see Telect Publication 129039 for detailed instructions on installation and wiring.

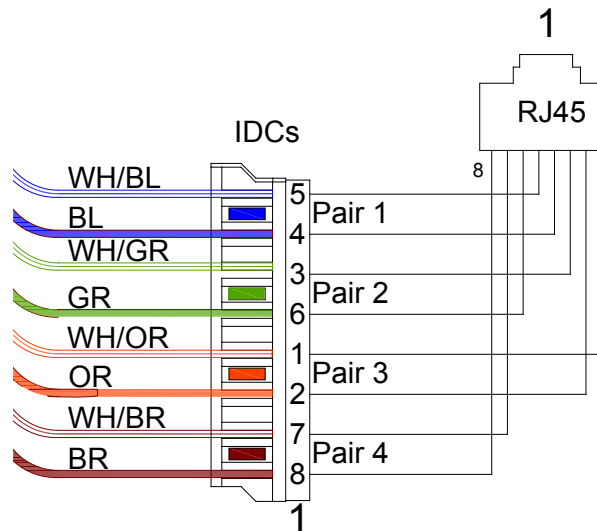

Figure 38 - Model ELF-9716-1700 Schematic

ELF System

Copper / Fiber :: ELF Family

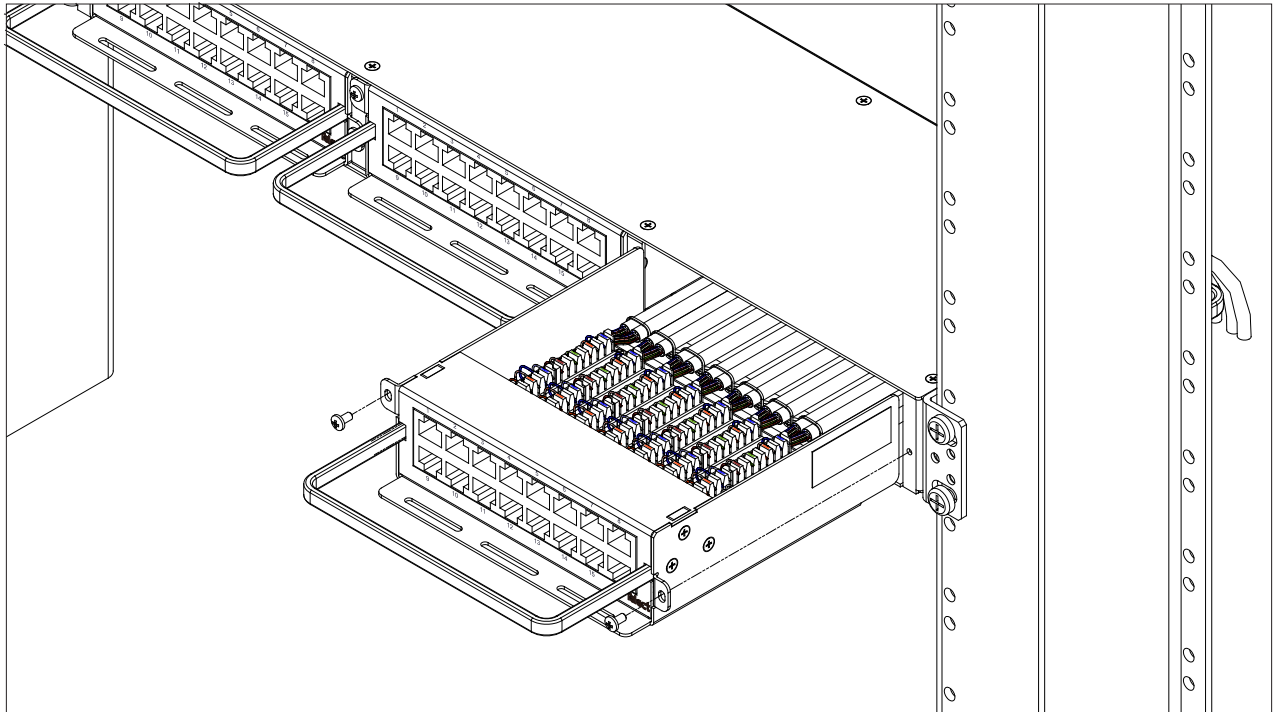

Figure 39 - Example of Model ELF-9716-1700 finished cable and wiring

5.3 ELF 12 x 4 Alarm Pin Block Module (Model ELF-0005-0001)

ELF 12 x 4 Alarm Pin Block
(Model ELF-0005-0001)

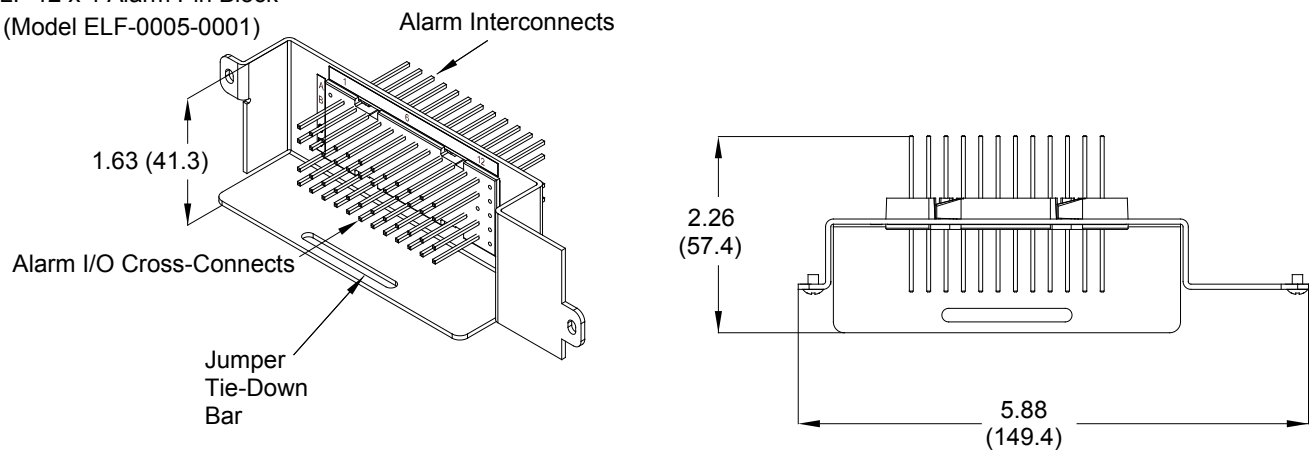

Figure 40 - Model ELF-0005-0001 Parts & Dimensions

Chapter 6: Service



CAUTION

CAUTION! Only qualified technicians may install and maintain this product.

6.1 Owner Maintenance

Telect's ELF chassis, enclosures, and modules do not need preventive maintenance

6.2 Service

Contact Technical Support (USA):

By e-mail: getinfo@telect.com

By phone: 888-821-4856 or 509-921-6161

6.2.1 In-Warranty Service

Contact your Telect equipment distributor, or call a Telect Customer Service Representative:

1-509-926-6000

Telect will repair or replace defective products within the limits of the warranty. See "Repacking for Shipment" in this section.

Call a Customer Service Representative for a Return Material Authorization (RMA) before returning any equipment.

6.2.2 Out-Of-Warranty Service

The procedure for out-of-warranty service is the same as for in-warranty service, except that Telect charges a processing fee, and you must submit a Purchase Order along with a Return Material Authorization (RMA) before returning equipment. Call a Customer Service Representative for help getting these forms.

The processing fee guarantees a repair estimate and is credited against actual material and labor costs.





6.3 Repacking For Shipment

1. Tag the equipment showing owner's name, address, and telephone number, together with a detailed description of the problem.
2. Use the original shipping container if possible. If you do not have it, package the equipment in a way to prevent shipping damage. Include the RMA inside the container and legibly print the RMA number on the outside of the package, near the shipping address
3. Insure the package.

ELF System

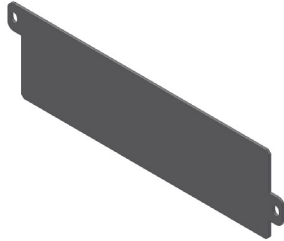
Copper / Fiber :: ELF Family

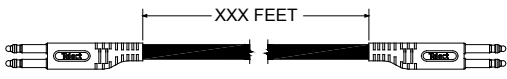
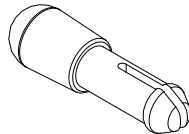
Chapter 7: Accessories

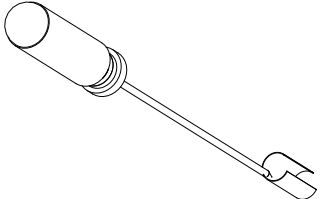
Description	Catalog No.	Illustration
Blank Face Plate (Includes Mounting Screws)	ELF-0000-0001	
Bantam		
Bantam Patch Cord, Single Plug	040-1000-xxx where xxx is the length in ft.	
Bantam Patch Cord. Dual Plug	040-2000-xxx where xxx is the length in ft.	
Bantam Circuit Guards Circuit Guard, BLK Circuit Guard, RED	101222-2 101222-3	
BNC		
Single RG59 without messenger wire	043-0111-xxx where xxx is length in ft	
Single 735A without messenger wire	043-0911-xxx where xxx is length in ft	
BNC Insertion & Removal Tool	097197	

ELF System

Copper / Fiber :: ELF Family

Description	Catalog No.	Illustration
Mini-WECO RG59	043-0122-xxx where xxx is length in ft	
735A	043-0922-xxx where xxx is length in ft	
Mini-WECO Looping Plug	301291	
Mini-WECO Terminating Plug	100293	
Mini-WECO Circuit Guard Plugs (Black or White)	PLG-MW-BLK or PLG-MW-WHT	
RJ48C Jumpers		
CAT 5e Patch Cords	EPCE-CT5E-BLXX where xx is length in ft	
CAT 6 Patch Cords	EPCE-CAT6-BLXX where xx is length in ft	

ELF System

Copper / Fiber :: ELF Family

Description	Catalog No.	Illustration														
Fiber Jumpers																
Single mode or 62.5/125 Multimode 2 mm Simplex SC or ST Connector on one end; SC or ST Connector on the other MegaWave or GigaWave Any length up to 999.0 ft or 999 m.	See telect.com to access cable configurator															
Circuit Designations (Self-adhesive circuit designation labels are provided with modules. Order the labels list here as replacements.)																
8 Terminations	123958	<table border="1" data-bbox="1203 800 1318 1024"> <tr><td>1</td></tr> <tr><td>2</td></tr> <tr><td>3</td></tr> <tr><td>4</td></tr> <tr><td>5</td></tr> <tr><td>6</td></tr> <tr><td>7</td></tr> <tr><td>8</td></tr> <tr><td>Telect <small>telect.com</small></td></tr> </table>	1	2	3	4	5	6	7	8	Telect <small>telect.com</small>					
1																
2																
3																
4																
5																
6																
7																
8																
Telect <small>telect.com</small>																
1 to 4 Terminations	129396	<table border="1" data-bbox="1203 1056 1318 1281"> <tr><td> </td></tr> <tr><td> </td></tr> <tr><td> </td></tr> <tr><td> </td></tr> <tr><td>Telect <small>telect.com</small></td></tr> </table>					Telect <small>telect.com</small>									
Telect <small>telect.com</small>																
12 Fiber Terminations	127380	<table border="1" data-bbox="1060 1304 1463 1520"> <tr><td>1</td><td>7</td></tr> <tr><td>2</td><td>8</td></tr> <tr><td>3</td><td>9</td></tr> <tr><td>4</td><td>10</td></tr> <tr><td>5</td><td>11</td></tr> <tr><td>6</td><td>12</td></tr> <tr><td colspan="2">Telect <small>connecting the future</small></td></tr> </table>	1	7	2	8	3	9	4	10	5	11	6	12	Telect <small>connecting the future</small>	
1	7															
2	8															
3	9															
4	10															
5	11															
6	12															
Telect <small>connecting the future</small>																

ELF System

Copper / Fiber :: ELF Family

This page intentionally left blank.