

Narada

stored energy solutions for a demanding world

12NPL210

The Narada Telecom Pure Lead range of VRLA batteries are well suited to provide battery backup in outdoor application long duration or outside plant application.

All Narada Telecom series batteries use CCPP plate technology and a patented post design offering exceptional service life.



Technical Features:

- Flame Retardant ABS Cover and Container, UL94 V-0, LOI>28%
- Patented copper alloy terminal design with epoxy TPS design for high reliability
- Low pressure one-way flame arresting valve(s) UL1989
- Specialized Absorbent Glass Mat (AGM) Sealed Technology, Recombination efficiency of 99.9%
- Up to 24 months of storage at 77°F (25°C)
- Initial capacity at 100%

Compliance and Safety:

- **ISO 9001:2000, ISO 14001:2004 and TL9000 certified facilities**
- UL Recognized Component 924, for use in or with listed UL1778, UL1989 and UL924 systems
- Compliant to SR-4228 & VZ.TPR.9802
- Compliant with EN 50272-2

Certified:

- VZ.TPR.9205, Issue 4, August 2009
- NEBS Version 4, Level 3 2012, Telcordia SR-3580, Issue 5, June 2012, Level 3
- VZ.NEBS.TE.NPI.2004.015
- Telcordia GR-1089-CORE, Issue 6
- Telcordia GR-63-CORE, Issue 4
- NEBS Earthquake Risk Seismic Zone 4
- IEC 60896-21:2004, IEC 60896-22:2004/BS6290 part 4

Transportation:

- Classified as Nonspillable UN 2800 and meets the Nonspillable criteria listed in DOT-CFR Title 49, 171-189 (d) (3) (i) and (ii) and exempt from CFR 49, Subchapter C requirements
- Meets transportation conditions of IMDG exemption 238, IATA/ICAO Special Provision A67 (Not Restricted)

Ah @ 8hr 1.75 vpc / 77°F (25°C)	202 Ah
Ah @ 10hr 1.80 vpc / 77°F (25°C)	210 Ah

Nominal Voltage	12V
Float Charge Voltage @25°C (2.23 – 2.27vpc)	13.4 – 13.6
Max. Charge Current (A) (5 hour rate @ 1.75vpc)	50.0 Amps

Electrolyte Absorbed H ₂ SO ₄	1.300
--	-------

Short Circuit Current (A)	2990 Amps
Internal Resistance (mΩ)	4.25

Terminal Type	Torque
M6-M (Front L Bracket)	78 in-lbs (8 ±1 Nm)
M6-F (Top Insert)	78 in-lbs (8 ±1 Nm)

Dimension	In	mm
Length	21.8	554
Length Base	20.9	530
Width	4.9	125
Overall Height	12.4	316

	Lbs.	Kg
Weight	132	60.0

CLEI	Pending	CPR	Pending
------	---------	-----	---------

NPL-Series

Operating Parameters

Float Charging Voltage	13.5V / 2.25vpc @ 77°F (25°C)
Equalize /Cycle	14.0V – 14.3V 2.33Vpc to 2.38Vpc @ 77°F (25°C)
See Operations and Maintenance Manual for specific guidelines and recharge times	

Charging Temperature Compensation	-2 mV/cell/°F > 77°F (-3.6 mV/cell /°C > 25°C)
	+2 mV/cell/°F < 77°F (+3.6 mV/cell/°C < 25°C)

Maximum AC Ripple (Charger)	0.5% RMS, 1.5% peak-to-peak for float charge voltage for best results
-----------------------------	---

Operating Temperature Range	
Nominal	+74°F (24°C) to 80°F (27°C)
Charge	-20°F (-28°C) to +122°F (50°C)
Discharge	-40°F (-40°C) to +140°F (60°C)
Storage Temperature Range	-4°F (-20°C) to +104°F (40°C)

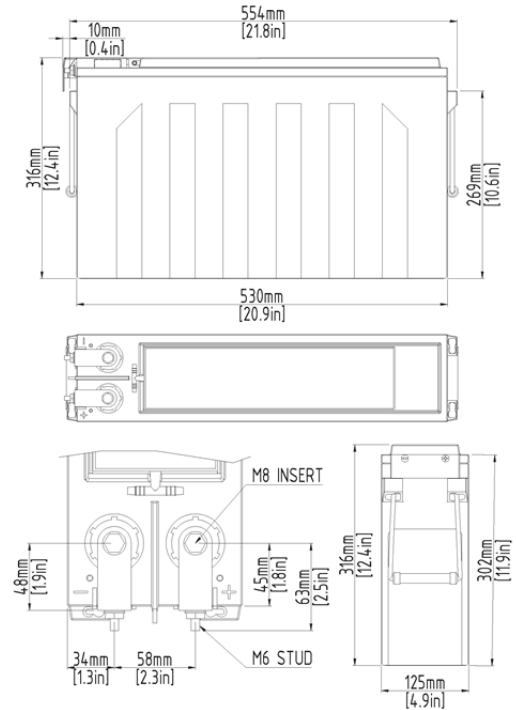

Constant Current Discharge (Amps) @ 77°F/25°C															
End vpc	5m	15m	30m	45m	1h	2h	3h	4h	5h	6h	8h	10h	12h	20h	24h
1.67	546	333	219	166	136	79.4	57.0	44.7	37.0	31.6	25.5	22.0	18.7	13.3	11.4
1.70	504	324	216	165	134	78.7	56.4	44.3	36.6	31.4	25.3	21.9	18.7	13.1	11.2
1.75	488	315	212	163	133	78.5	56.4	44.3	36.6	31.3	25.2	21.7	18.5	12.9	11.0
1.80	445	286	200	157	131	78.3	56.3	44.2	36.5	31.1	25.0	21.0	17.5	11.1	9.03
1.83	369	257	188	152	129	78.2	56.2	44.0	36.4	30.9	24.3	20.1	17.2	10.8	8.99
1.85	344	244	180	146	124	78.0	55.8	43.8	36.2	30.7	23.8	19.7	17.0	10.4	8.74
1.86	326	231	171	139	118	74.8	55.0	43.3	35.6	30.0	23.5	19.6	16.2	9.64	7.93

Constant Power Discharge (Watt/Cell) @ 77°F/25°C															
End vpc	5m	15m	30m	45m	1h	2h	3h	4h	5h	6h	8h	10h	12h	20h	24h
1.67	947	623	422	325	265	157	113	89.3	74.9	63.4	49.6	44.5	38.1	24.7	21.1
1.70	891	597	410	318	262	157	113	89.3	74.7	63.3	49.4	44.2	37.6	23.9	20.4
1.75	862	580	403	314	259	156	113	89.2	74.6	63.2	49.4	44.0	37.3	23.4	19.8
1.80	796	539	383	303	253	155	113	89.0	74.4	63.1	49.1	43.2	36.3	21.8	18.0
1.83	671	481	358	292	248	155	113	88.9	74.2	62.9	48.0	41.4	34.0	19.9	17.0
1.85	631	459	346	282	241	155	112	88.7	74.1	62.7	47.4	40.8	33.5	18.5	15.8
1.86	603	439	332	272	232	150	111	88.1	72.6	61.6	46.7	40.5	33.4	17.3	14.8

China: **Narada**
 NARADA POWER SOURCE CO.,LTD.
 No.459 Wensan Road, Hangzhou, Zhejiang, P.R.China
 Tel:+86-571-28827013 Fax:+86-571-85126942
 Website:www.en.naradabattery.com E-mail: intl@narada.biz

MPiNarada MPI-Narada
 44 Oak St
 Newton, MA 02464
 Tel: 800-982-4339
 sales@mpinarada.com www.mpinarada.com

