

ALLIANCE is SOLiD's multi-operator, neutral host Distributed Antenna System (DAS) that efficiently delivers wireless RF signals into any indoor or outdoor location difficult to cover with traditional macro networks.

In ALLIANCE, the Base Station Interface Unit (BIU) is the central input point for all source signals sent and received over the DAS.

The Base Station Interface Unit features:

- Multiple frequencies in a single unit
- RF power control to guarantee power for each operator as configured in management software.
- Plug-in components for adding additional operators without the need for additional architecture
- Advanced filtering capabilities. 4G Certified. MIMO capable
- Auto Level Control (ALC) uplink and downlink for each service

Operation

The BTS Interface Unit (BIU) receives downlink signals from the base station (BTS) or bi-directional amplifier (BDA). Each signal is then independently monitored, filtered, conditioned, and controlled automatically in the BIU and transmitted to the system’s Optic Distribution Units (ODUs). The Donor Optic Units (DOUs) in the ODU converts the RF signals to optical signals and transmits them via fiber to the Remote Optic Units (ROUs).

At the ROU, signals are amplified and sent via coax to the remote antennas placed throughout the building or campus. For the uplink path, the process is reversed allowing the BIU to route each frequency to the proper operator.

TX input power range for the BIU is -20 dBm to +10 dBm. Variable attenuation is available up to 30 dB for both the TX and RX paths. Currently supported bands are shown in the next table.

Each BIU can support 17 discrete inputs (16 commercial and 1 VHF/UHF). For deployments with high capacity requirements, the DAS can support two BIUs configured as a main/secondary pair connected with the BIU combiner. Two BIUs can support up to 34 discrete inputs.

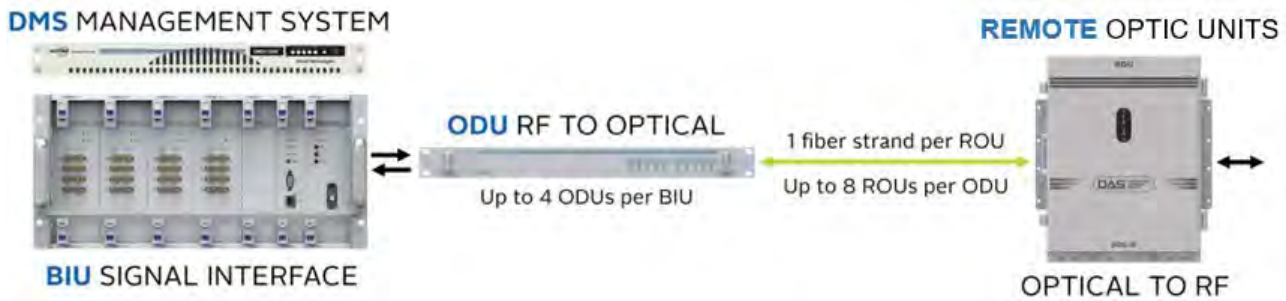

RF Parameters

Frequency Band	Downlink (Tx)	Uplink (Rx)
	Frequency (MHz)	Frequency (MHz)
700LTE Full Band	729-756	699-716 / 777-787
700LTE Full Band + FirstNet	729-768	699-716 / 777-798
700PS (Incl. FirstNet)	758-775	788-805
800 Public Safety	851-869	806-824
800 Sprint + 850C	862-894	817-849
900+Paging	929-941	896-902
1900PCS	1930-1995	1850-1915
AWS 1+3	2110-2180	1710-1780
2300 WCS	2350-2360	2305-2315
2500TDD LTE	2496.8-2690	2496.8-2690
VHF	136-174	136-174
UHF (Band Selectable)	Band1: 380-434 Band2: 396-450 Band3: 450-512	Band1: 380-434 Band2: 396-450 Band3: 450-512

BIU Components



Component	Description
1. Main Drive BTS Unit (MDBU)	Amplifies & adjusts downlink and uplink RF signal. Provides Automatic Level Control (ALC) to ensure each signal receives equal maximum power levels. Maximum 4 MDBUs in a single BIU. LED Status indicators: Power On and alarm conditions
2. MDBU / RF Monitor Ports	Monitor RF downlink (TX) input and uplink (RX) output levels. Measured level is -20dB below actual level.
3. Main Central Processor Unit (MCPU)	Controls and monitors system status. Includes RS232 port and Ethernet port local and remote monitoring. Status indicators: Power On and TX/RX communication status. Reset switch restarts CPU.
4. MCPU / RS232 port	Connection for PC/laptop for local monitoring/configuring DAS devices
5. MCPU / Ethernet port	Connection for IP network for remote access to system
6. Main Power Supply Unit (MPSU)	Input power: DC -48VDC, Output power: 9V, 6V. Test ports: Measure DC power values (+6vdc and +9vdc) Status indicators: Power On and DC alarm status
7. MPSU / Power switch	Power ON/OFF switch
8. Main Combiner Divider Unit (MCDU)	Combines downlink signals received from MDBUs and from VHF+UHF signal ports. Splits them for delivery to Optic Distribution Units (ODUs). For reverse path, MCDU combines uplink signals from ODU's and then divides them for delivery to individual MDBUs.
DC Power Supply (RMP_480)	Separate unit that supplies power to BIU: - 48 VDC / 480 W (not shown)

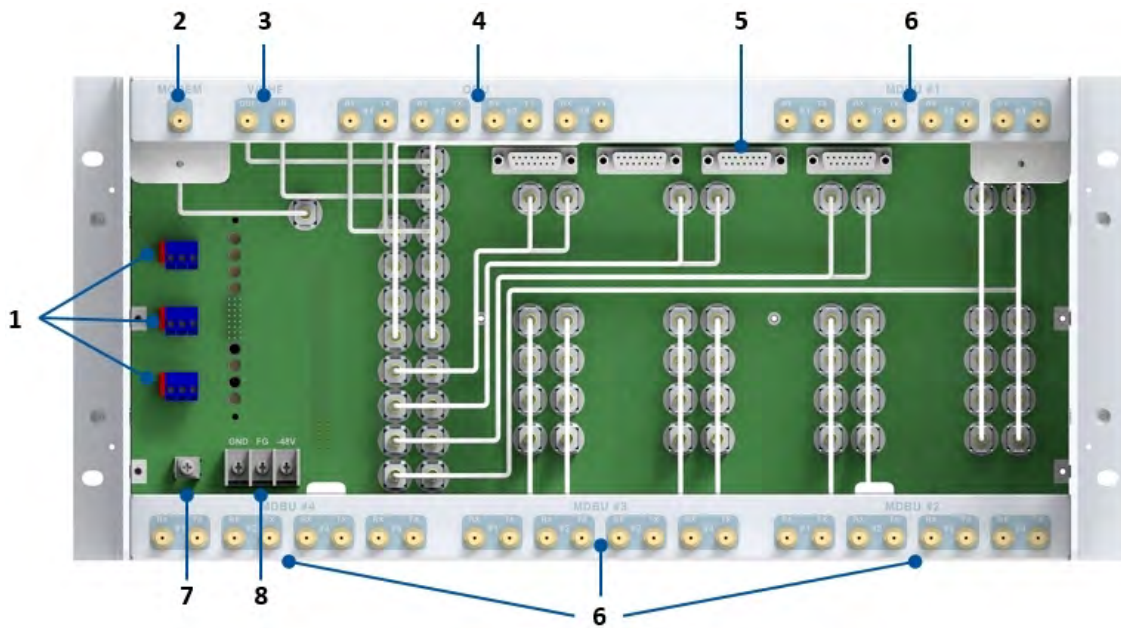

Item	Description
1. External Alarm Contacts	Input/output terminal for dry contacts
2. GSM Modem Port	GSM Modem terminal for connecting to IP network (Optional)
3. VHF+UHF I/O Port	RF signal interface terminal of VHF+UHF
4. ODU I/O Port	RF signal interface terminal for ODUs
5. ODU Signal Port	Power and signal interface terminal for ODUs
6. BTS (BDA) I/O Port	Input/output interface terminal for BTS (or BDA)
7. Ground Port	System ground terminal
8. DC Input Port	Input terminal for DC -48V coming from DC power supply shelf

Specifications

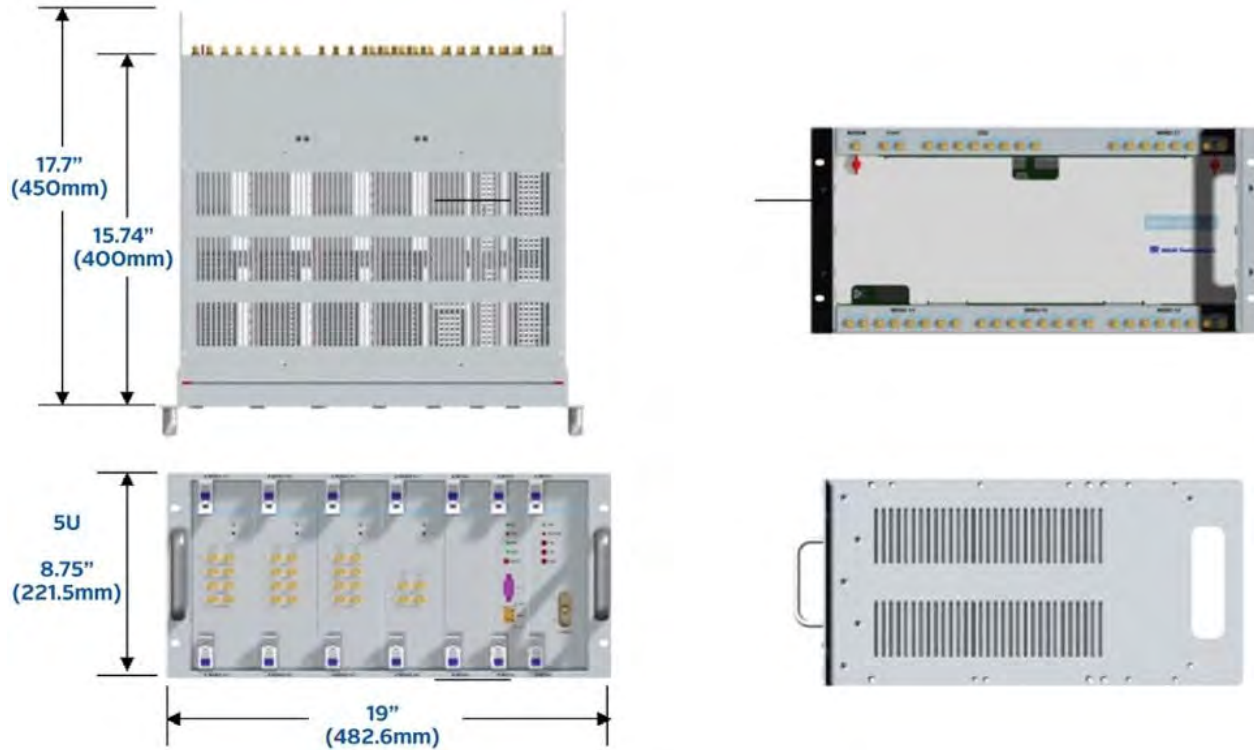

Parameter		Description
RF Connectors		4 SMA type (simplex), female (per MDBU)
Monitor RF Ports on MDBU		Monitor RF input and output levels. Measured level is 20dB below actual level.
External Alarm Connector		Terminal block, 3 dry contacts (all output or 2 output / 1input)
Serial Interface Connector		RS232 9-pin D-sub, male (for connecting management PC)
LED Status Indicators ● ● Green = Normal Operation Red = No Power / Link Failure / Error Condition / Active Alarm		MDBU: Power On status, Alarm status MCPU: Power On status, TX Communication, RX Communication, Alarm status MPSU Power On status DC Alarm status
DC Power		Normal range: -48 VDC. Operating range: -40.8 to -57.6VDC
Total Attenuation per port	Downlink	Management Software: +30dB variable in 0.5dB increments
	Uplink	Management Software: +30dB configurable in 0.5dB increments. (Note: this attenuator is shared with the ALC feature. Any hard-coded attenuation will reduce the ALC action by the amount of the hard-coded attenuation.)
Power Consumption	Main	215W Fully loaded (4 MDBUs) covering bands: 700/800/850/1900/2100/2500 and powering 4 fully loaded ODUs (Two DOUs in each ODU). Total power consumption will vary depending on configuration. BIU is powered by a separate DC Power Supply shelf (RMP-480).
	Secondary	95W with 4 MDBUs
Mounting		Mounts in standard 19" rack.
Enclosure Dimensions		19"W x 8.75"H (5U) x 17.7"D (482.6 x 221.5 x 450mm) (fits 19" rack)
Weight		49.27 lbs. (22.35 kg) fully loaded
Operating Temperature		14 to 122°F (-10 to +50°C) ambient temperature

Standards / Certifications

Specification	Description
EMC	EN 301 489-01, EN 301-489-8, EN 301-489-23
Type Approval & Certification	EN60950-1

Part Numbers

Product Description	Part Number
Base Station Interface Unit - For use with Rel. 6 (Input Power -48VDC. Power supply not included. Order RMP_480 separately.)	BIU_C
BIU Combiner (Doubles Input Modules on Single Fiber Strand)	BIU_Combiner
Blank BIU Module for the BIU	BIU_B (BIU BLANK)
1900 MHz Input Module for the BIU	MDBU_1900P
1900 MHz Input Module for the BIU, Channel B for MIMO Applications	MDBU_1900P_M
800MHz & 900MHz Input Module for the BIU	MDBU_800PS_900I_PA
800MHz (Sprint only) & 850MHz & 700MHz LTE Full Band + FirstNet Module for the BIU	MDBU_8085_700FB_FN
850MHz & 700MHz Public Safety Bands Input Module for the BIU, includes FirstNet	MDBU_850C_700PS
2100MHz (AWS 1+3) Input Module for the BIU	MDBU_AWS13
2500 MHz TDD Input Module for BIU; Duplexed Input	MDBU_2500_60TDD
2500MHz TDD & 2300MHz Input Module for BIU	MDBU_23_25
ALLIANCE Power Supply - 48 VDC / 480 W	RMP_480



SOLiD Gear, Inc.
 800 Klein Road, Suite 200
 Plano, TX 75074
 PHONE: 888.409.9997
 EMAIL: sales@solid.com
 WEB: www.solid.com

