

# *Westell*

## Fuse Panel Technical Practice

**NPGMT1012**  
15/15 GMT  
NEBS Level 3 Verified

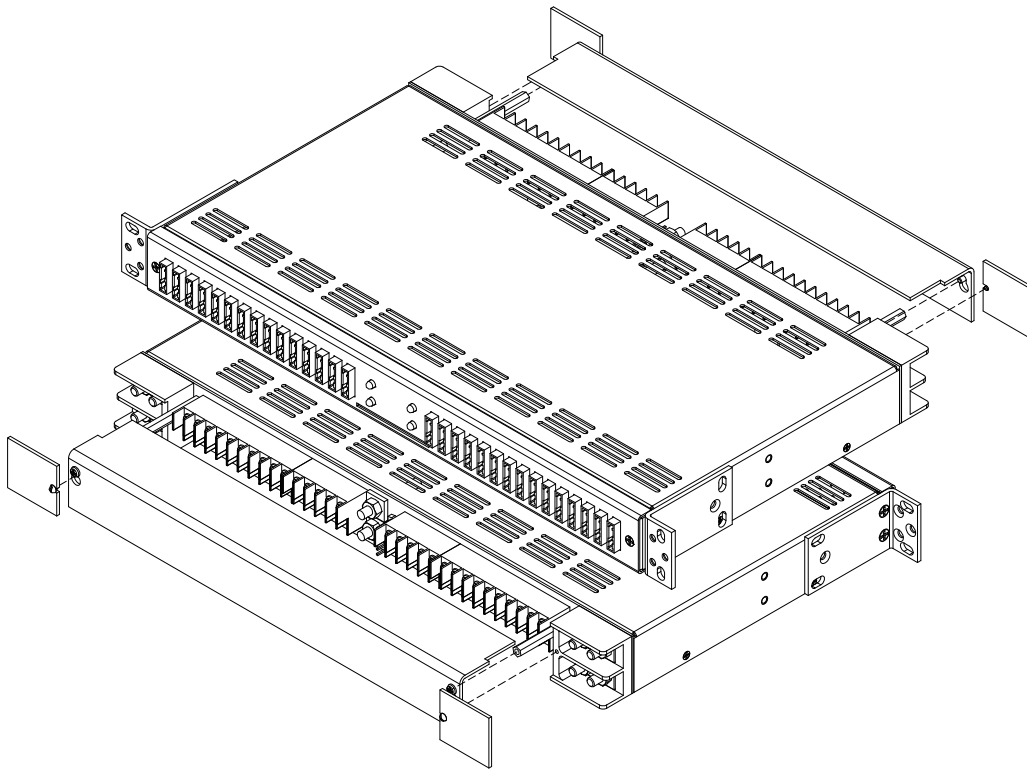

### FEATURES



- 2 isolated groups (busses) of 15 GMT style fuses in each (20Amps/GMT position max).
- Polarity insensitive (+/-24 or +/- 48 Vdc) battery voltage.
- This panel can operate at 200 Amps of output current per panel (100 Amps per Bus).
- Barrier terminal strips for fused outputs and isolated returns (grounds).
- Two sets of Form C relay contacts are provided to extend alarms.
- One set of alarm contacts for each; Bus A, and Bus B Alarm.
- Single 1.75" mounting height (single panel space).
- Mounting brackets are supplied for 1" & 1-3/4" spacing and are universal for 19" and 23" racks, with flush and offset mounting options.
- NEBS level 3 verified, with zone 4 earthquake.
- UL Listed

# 1. GENERAL DESCRIPTION

1.1. The Noran Tel NPGMT1012 Fuse Panel provides up to 30 circuits for the distribution of DC power to equipment. Each of the 30 circuits is individually protected by a GMT style telecommunication fuse (20A max) located on the panel's faceplate. Alarm circuits are provided to indicate and extend alarm conditions when faults occur. Normal Operation LEDs are provided to indicate the status of each bus in the panel.

1.2. Input wiring is connected to a high current, 2-hole lug input block located at the rear of the panel. Each group of fuses or bus has its own completely isolated inputs, allowing the distribution of two battery voltages through the same panel.

1.3. The power is distributed to the load side equipment through GMT style fuses. There are 15 fuses per fuse group and two groups per panel. Each fuse position is available for installer connection at the rear of the panel. A designation card is provided for keeping records of which position is connected to which equipment and what amperage is to be used.

1.4. Alarm circuits are provided to alert service personnel of fault conditions. A fuse alarm is a blown fuse within a given bus. A red fuse alarm LED  on the faceplate will illuminate when a fuse alarm condition is present. As well, the green Normal Operation LED  will extinguish to signal a fuse alarm or input power failure and the appropriate relay contacts will change states. These fuse panels have common (C), normally open (NO) and normally closed (NC) terminals for alarms. Note, the use of the alarm contacts is optional, if you do not wish to extend the alarms, you don't have to do anything with the alarm pins. The "Normal" condition of the relay exists when the panel is powered up without any blown fuses. The local alarm LEDs are located on the front of the panel as shown in Figure 1.4.1

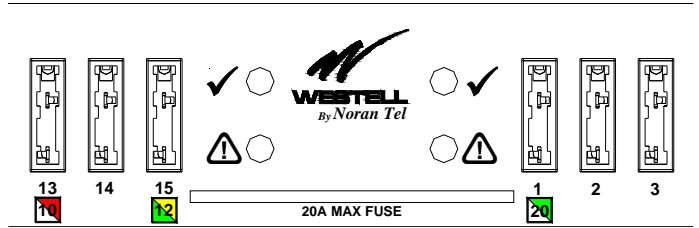

Figure 1.4.1

1.5. These Fuse Panels are made from 0.050" steel and painted off-white. Single rack height panels are shipped with universal brackets (1" & 1-3/4" spacing) that will fit both 19" and 23" wide racks and use only one 1.75" panel space. The panel has a clear L shaped plastic shield to protect the wiring connections on the back of the panel. The panel is shipped with 30 dummy fuses.

## 2. APPLICATION



2.1. The NPGMT1012 Fuse Panels are designed to be used in the distribution of DC power. They are rack mount panels that can provide fused DC power to up to 30 individual circuits, or 15 pieces of equipment, providing redundant battery feeds to each.

2.2 The NPGMT family fuse panels are suitable for installation as part of a Common Bonding Network (CBN). As well, this family of fuse panels is suitable for restricted access locations in Network Telecommunications Facilities and OSP.

## 3. CIRCUIT DESCRIPTION

3.1. Power is connected to the fuse panel via 1/4" studs on 5/8" centers located at the rear of the panel (torque 5.5 ft-lbs). These inputs are high current stud blocks that supply current to the fuse panel. Connect the battery return cable to the stud input that is labeled "RTN" and the Battery supply cable to the terminals labeled "BAT".

3.2. Distribution of current from each bus is provided by GMT style fuses. Each bus has 15 fuse holders for distribution, the fuses are labeled 1 to 15 on each bus. Each fuse position is made available at the rear of the fuse panel. Maximum fuse size allowed in each position is 20 Amps, provided the maximum bus current or BDFB fuse

LED	SYMBOL	SIGNIFICANCE
GREEN		NORMAL OPERATION
RED		BLOWN FUSE

is not exceeded (each bus is rated at 100Amps max).

3.3. Fuse Alarm circuitry provides 1 set of form “C” contacts (C, NO and NC) for each bus (Bus A, and Bus B). In the event of a fuse alarm or loss of input power, the proper relay will change states, providing a connection between the Normally Open “NO” and Common “C” terminals for that bus. The normally closed “NC” terminal will open to high impedance.

#### 4. INSTALLATION

**Please read completely before beginning.**

**WARNING:** Installation should only be performed by an experienced Installer familiar with DC power distribution systems.

***This product must be installed within a RESTRICTED ACCESS LOCATION where access is through the use of a tool, lock and key, or other means of security, and is controlled by the authority responsible for the location. This product must be installed and maintained by TRAINED SERVICE PERSONNEL ONLY.***

4.1. Unpack and inspect the Noran Tel Fuse Panel for possible damage incurred during shipping. If damage is found, file a claim immediately with the carrier, and notify the Noran Tel Customer Service Department.

4.2. Once the panel is unpacked, verify that there are three mounting brackets. The bracket with the vertical slot is used on both 1” and 1-3/4” spacing. There will be two brackets with horizontal slots, these will fit 1” or 1-3/4” spacing. All three brackets are universal for 19” and 23” rack mount spacing (see figure 4.2.1) and can be mounted so the panel can be installed for a flush mounting or 5” offset. Adjust the position and orientation of the correct mounting brackets on the fuse panel, such that it will fit the rack you wish to mount the panel in. Please see drawing 1012-16 on page 6 for mounting bracket configurations.

**Rack Mount Instructions:**

**Elevated Operating Ambient** - For closed or multi-unit rack assemblies, the operating ambient may be greater than room ambient. Take care to install the equipment in an environment compatible with the maximum ambient temperature (T<sub>ma</sub>) specified by the manufacturer.

**Reduced air flow** - Installation of the equipment in a rack should be such that the amount of air flow required for safe operation is not compromised.

**Mechanical Loading** - Mounting of the equipment in the rack should be such that a hazardous condition is not achieved due to uneven mechanical loading.

**Circuit Overloading** - Consideration should be given to the connection of the equipment to the supply circuit and the effect that overloading of the circuits might have on overcurrent protection and supply wiring. Appropriate consideration of equipment nameplate ratings should be used when addressing this concern.

**Reliable earthing** - Reliable earthing of rack-mounted equipment should be maintained. Particular attention should be given to supply connections other than direct connections to the branch circuit.

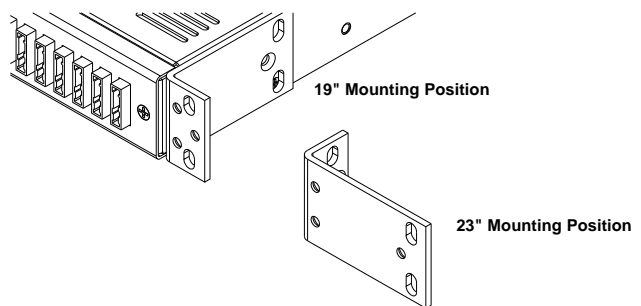

Figure 4.2.1

4.3. Mount the panel on the equipment rack using the thread forming #12-24 rack mounting screws and tooth lock washers provided.

**WARNING:** For safety reasons all wiring should be done with all power sources removed (when possible).

**Note:** A readily accessible disconnect device shall be incorporated in the building installation wiring.

4.4. Remove the distribution fuse feeding the input cables that are to be connected to the new panel. Attach the input cables to the input terminal block in accordance to the National Electrical Code, ANSI/NFPA, and Canadian Electrical code. Hook up the input cables to the input terminal block on the fuse panel (“BAT” & “RTN” for each bus). Each high current input terminal uses a two hole compression lug (1/4” on 5/8”, torque to 5.5 ft-lbs). A two hole lug must be used for proper operation (see fig 4.4.1)

**Note:** The supply source must be limited to an instantaneous short-circuit current not to exceed 450 Amps.

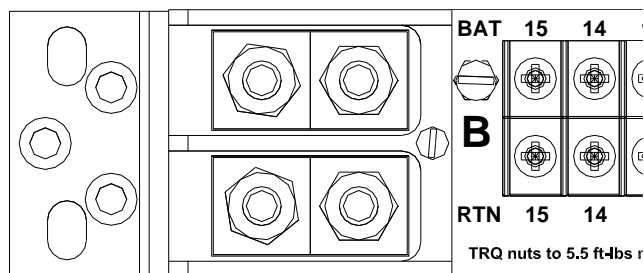

Figure 4.4.1

4.5. The battery outputs (“BAT”) are available at the terminal blocks (#6 screw torque to 9 in-lbs, up to 10awg fork) at the rear of the panel. Each fuse position is numbered and that circuit is available at the terminal block position with the same number.

4.6. All battery return (“RTN”) connections are also terminated on barrier strips (#6 screw, up to 10awg fork). Note, these returns are isolated from the chassis frame.

4.7. This panel has Bus A, and Bus B alarm contacts. Each alarm has a common (C), normally open (NO) and normally closed (NC) alarm contact. In an alarm the “C” contact will short to the “NO” contact, and the “NC” will open. Wire-wrap the alarm connections as per your alarm system requirements. Noran Tel recommends you fuse the alarm battery supply (ABS) to 1A or less to protect the alarm wiring and circuitry.

4.8. **CHASSIS GROUND;** For safety reasons, and as recommended by NEBS, the chassis should be electrically connected to the rack ground. From step 4.3. the panel should already be ground to the rack via the #12-24 thread forming rack screws and outside tooth lock washers. In addition to grounding via the mounting brackets, it is recommended you ground the chassis using a ground cable and the two ¼” bolts and locks on back of chassis (1/4” bolt torque; 5.5ft-lbs or 7.5Nm). Consult the National Electric Code, ANSI/NFPA, and Canadian Electrical code for AWG sizes.

4.9. The input wiring feeding this panel should be protected by a Listed fuse/breaker rated for at least 60Vdc, with a trip rating of 125 Amps Max. With input wiring connected and this input fuse installed, the panel should power up with the Normal Operation LED ✓ illuminated and without any red LEDs ⚠ illuminated, and the relays should be in the “Normal” state (“C” connected to “NC”).

4.10. If you wish to verify the fuse alarm circuit, you can insert a blown fuse into one of the empty fuse holders. The red Fuse Alarm LED ⚠ should light and the Normal Operation LED ✓ should extinguish and the appropriate alarm extension relay should change states to extend the alarm.

4.11. Install panel output distribution fuses as required. Be sure to size fuses to no more than 70% of their rating (14A max for a 20A fuse). Fuses are not included with this panel. Fuse ratings should be selected to match the load equipment ratings. Once the appropriate fuses have been selected, the fuse information for F1-F15 on BUS A and F1-F15 on BUS B is to be recorded at the time of installation. Use the provided designation card to keep a record of which equipment is connected to which circuit and what the fuse rating is. Be careful not to overload the panel bus or BDFB fuse position rating supplying the panel.

4.12 Install amperage marking labels as required below each fuse for identification of circuit rating (see fig 1.4.1). For fuse color codes please see table 4.12.1

Amps	Color Code
18/100 A	Yellow
2/10 A	Red/Black
1/4 A	Violet
3/8 A	Gray/White
1/2 A	Red
65/100 A	Black
3/4 A	Brown
1 A	Gray
1 1/3 A	White
1 1/2 A	White/Yellow
2 A	Orange
2 1/2 A	White/Orange
3 A	Blue
3 1/2 A	White/Blue
4 A	White/Brown
5 A	Green
7 1/2 A	Black/White
10 A	Red/White
12 A	Yellow/Green
15 A	Red/Blue
20 A	Green/White

Table 4.12.1

## 5. SPECIFICATIONS

5.1. Voltage	-/+24 or +/-48 VDC Typical -/+22 to +/-58 VDC Max.	5.12. Dimensions	1¾ H, 17 W, 10½ D (excluding brackets)
5.2. Fuse Size	60Vdc, 0.18 to 20 Amps Max* 450A @60Vdc Interrupt rating (Littelfuse Type 481 Series)	5.13. Rack Mounting	19" and 23" Racks for 1" or 1-3/4" Panel Spaces
5.3. Current/Bus	100 Amps Max.**	5.14. Weight	Appx 8 Lbs
5.4. Current/Panel	200 Amps Max.**	5.15. Operating Temp.	-40° to +65°C (-40° to +149°F)
5.5. Output Fuse	GMT Style Fuse Holders	5.16. Color	Off White
5.6. Output/Bus	15 Fuses (30 per panel)	5.17. Short Circuit withstand Rating	450A (max)
5.7. Output/Panel	2 Busses per Panel		
5.8. Input Block	Two ¼" Studs on 5/8 centers Max std lug is 1 AWG Max lug width = 0.710"		
5.9. Output Block	#22 AWG to 12 AWG wire Or fork/ring for #6 screw, 10AWG forks/rings will work Max lug width = 0.320"		
5.10. Alarm Block	0.045" sq wire wrap pin		
5.11. Relay Current	1 Amp/58Vdc max		

\*We recommend that you size fuses such that they do not run at more than 70% of their rating. Thus a 20A fuse should not be run at more than 14 A.

\*\*The sum of the fuse ratings must not exceed the bus rating.

## Compatible lugs for Input Block

2 hole compression lugs for 1/4" studs on 5/8" centers (torque 5.5ft-lbs) example;

Panduit® LCD1-14A 1awg wire  
LCD2-14A 2awg wire  
LCD4-14A 4awg wire  
LCD6-14A 6awg wire  
LCD8-14A 8awg wire

The Panduit® CT-1700 crimping tool can be used for securing wire to any of these lugs.

Input wiring should be rated 90°C or better and fused at 125% of total Bus current (ie: up to 125Amps MAX rated input fuse/breaker)

**Output lugs** (locking fork recommended):  
Ring or fork for #6 screw (up to 10awg).  
(Torque to 9 in-lbs, use wire rated 90°C or better.

**NOTE:** If fuse size is not specified in the equipment manual, fuses should be selected such that they do not run at more than 70% of their rating. When installing fuses, the sum of the fuses installed in each bus should not exceed the bus rating (100 Amps) or input fuse rating.

## 6. TECHNICAL SERVICES

6.1 If technical or customer assistance is required, contact Westell

6.2 This equipment is identified by a model number. Be sure to have the model number and serial number available when making inquiries about the equipment.

## 7. WARRANTY & REPAIRS

7.1 Westell warrants this product to be free of defects at the time of shipment. Westell also warrants this product to be fully functional for the time period specified by the terms and conditions governing the sale of the product. Any attempt to repair or modify the equipment by anyone other than an authorized Westell representative will void the warranty.

7.2 Westell will repair or replace any defective Westell equipment without cost during the warranty period if the unit is defective for any reason other than abuse, improper use, or improper installation. To return defective equipment, first request a Return Material Authorization (RMA) number

from Westell by calling or emailing (Customer Service) at the address below. Once an RMA number is obtained, return the defective unit (freight prepaid), along with a brief problem description, to the address we will provide to you when you contact us.

Replacements will be shipped in the fastest manner consistent with the urgency of the situation. Westell will continue to repair or replace faulty equipment beyond the warranty period for a nominal charge. Contact Westell for details.

REV	Qty	Description or Release Note	ECN	CKD	APD	DATE
A		Original				07 Feb 11
B						
C						
D						
E						
F						

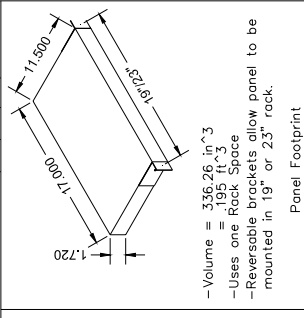
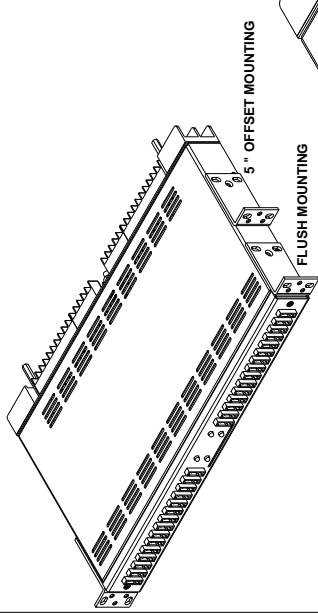
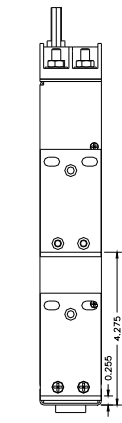

-Volume = 336.26 in<sup>3</sup>  
 = 195 ft<sup>3</sup>  
 -Uses one Rack Space  
 -Reversible brackets allow panel to be mounted in 19" or 23" rack.  
 Panel Footprint

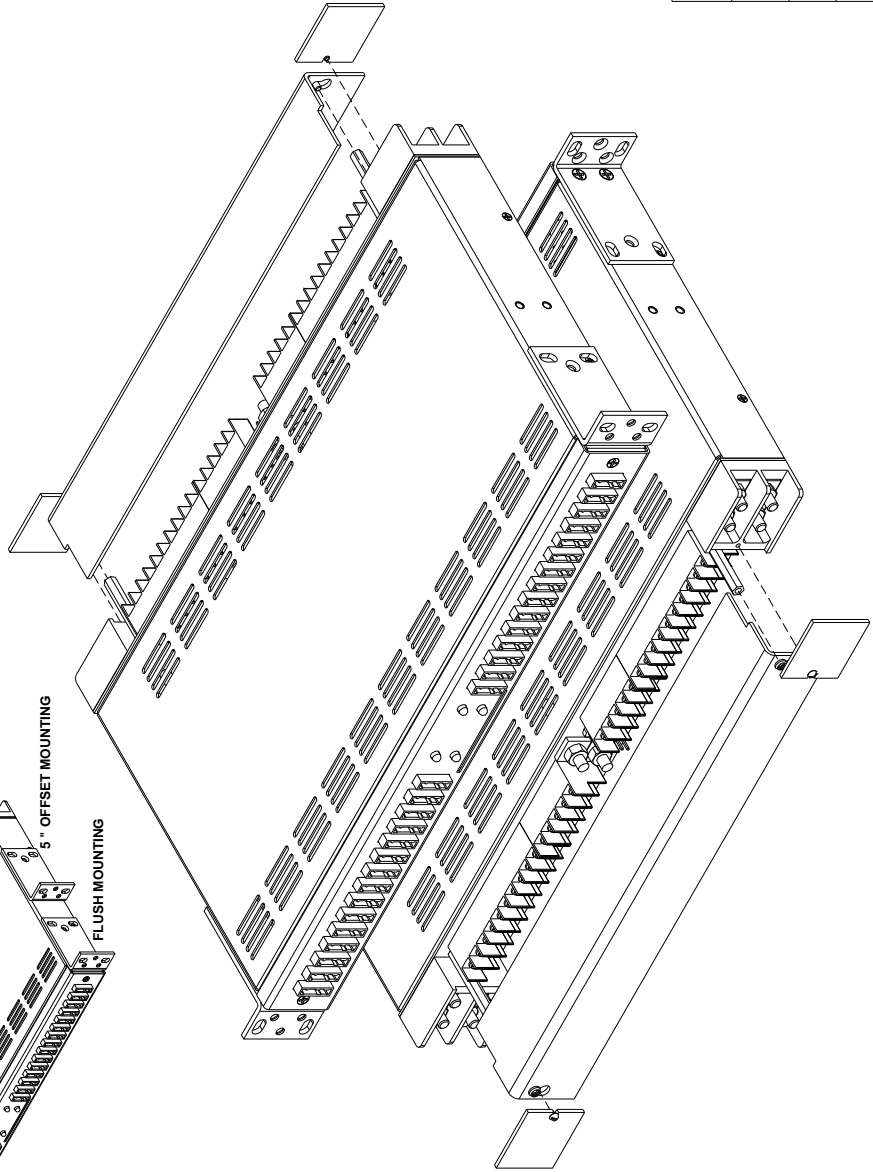
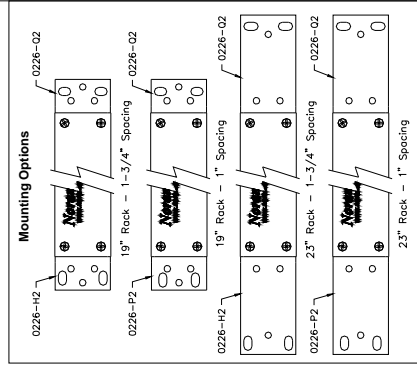

**Noran Tel**  
 COPYRIGHT / DO NOT DUPLICATE

NPGMT1012 Complete Panel Illustration Drawing	
Drawing Number: 1012-16	Rev: 1
Drawn with: AutoCAD	
Computer File: Noran Tel use only 1012-16A	
Date: 07 February 11	Plotted Scale: 1:2
Drawn by: S. Dolinsky	Sheet: 1 of 1

REV	Qty	Description or Release Note	ECN	CKD	APD	DATE
A		Original				07 Feb 11

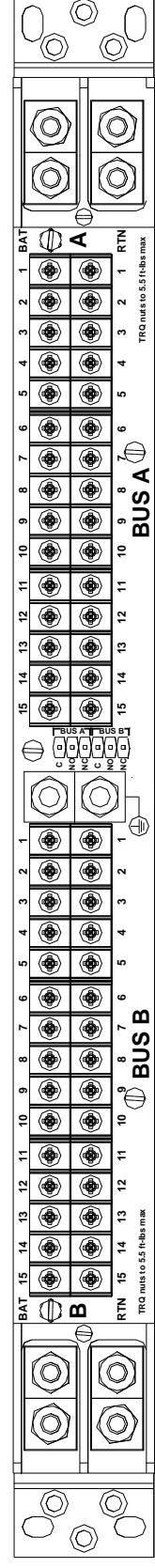
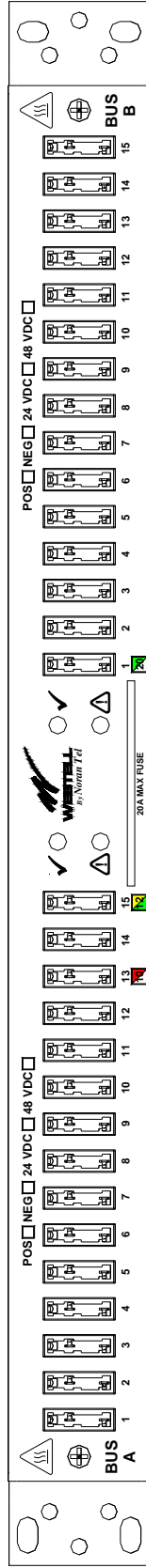

**Noran Tel**

COPYRIGHT / DO NOT DUPLICATE

Front/Rear Views  
Illustration Drawing

Drawing Number: 1012-17  
Rev: AutoCAD by Autodesk

Date: 07 February 11  
Plotted Scale: NTS

Computer File: Noran Tel use only  
1012-17A

Drawn by: S. Dolinsky  
Sheet: 1 of 1



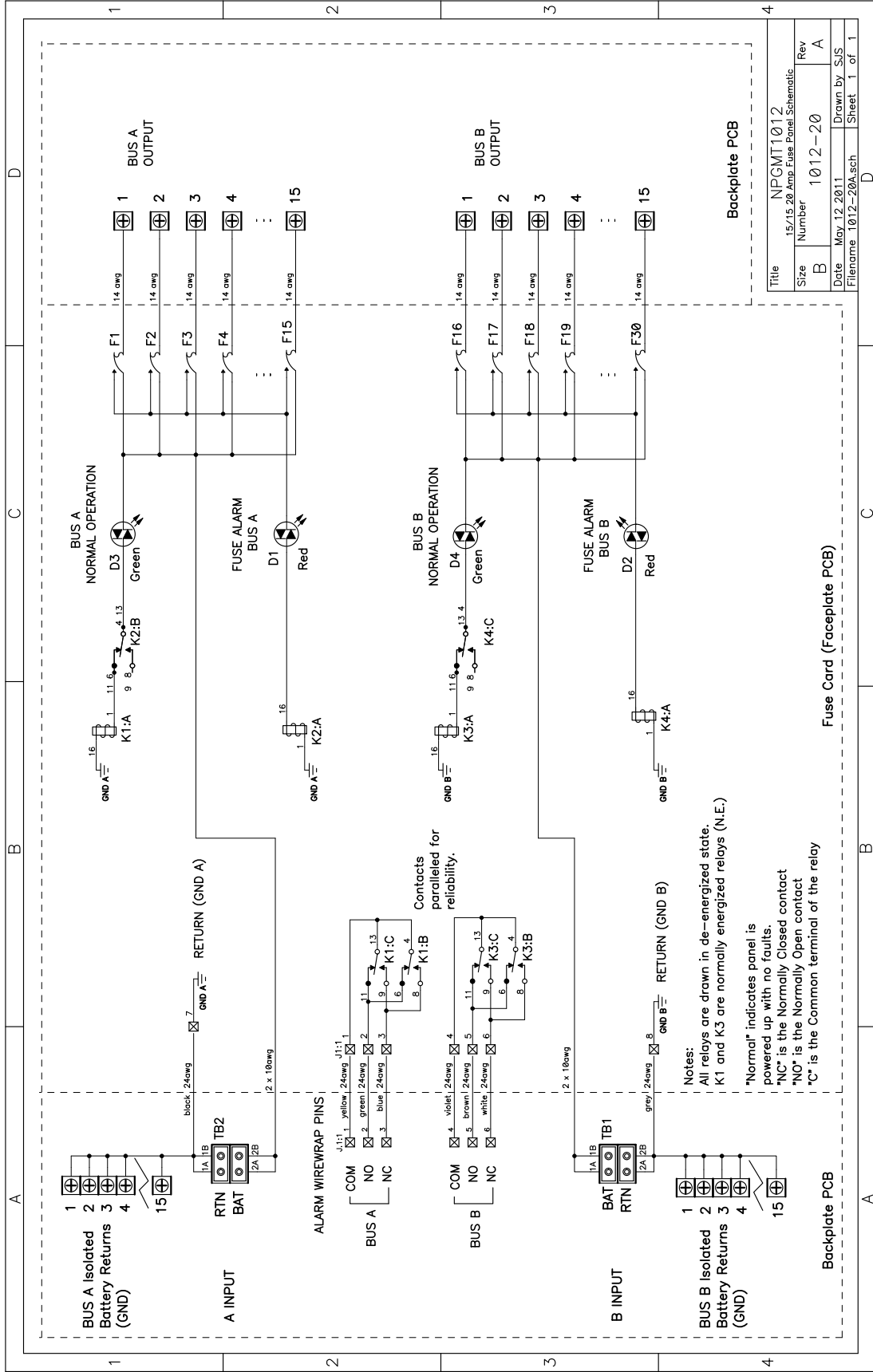

Title	NPGMT1012		
Size	15/15 20 Amp Fuse Panel Schematic	Rev	A
Number	1012-20	Rev	A
Date	May 12 2011	Drawn by	SJS
Filename	1012-20A.sch	Sheet	1 of 1